

Rinnai

INFINITY

REU-2007W

REU-2008W

REU-2408W

REU-2424W

SERVICE MANUAL

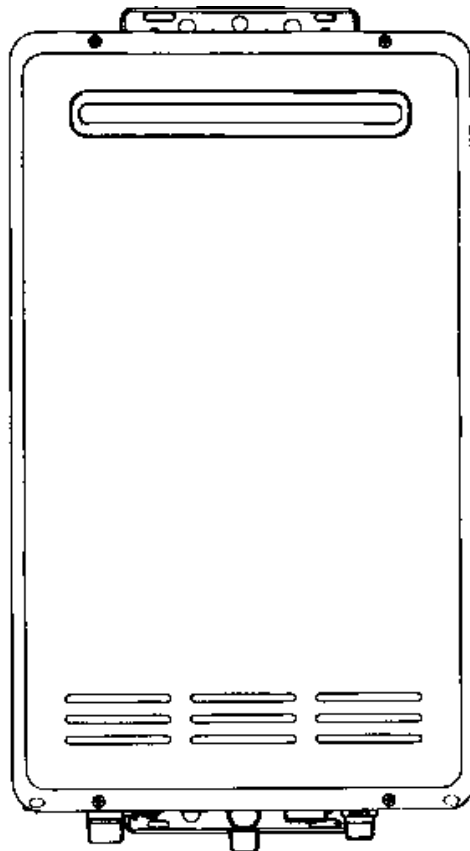

Infinity Compact Continuous Flow Gas Hot Water System

Proudly a member of The Australian Gas Association.
All of our products are AGA tested and approved.



**Quality
Endorsed
Company**

ISO 9002 Lic 4983
Standards Australia

Distributed and serviced in Australia under a Quality System certified as complying with ISO 9002 by Quality Assurance Services.

Rinnai New Zealand has been certified to ISO 9001 Quality Assurance by Telarc.



**Quality
Endorsed
Company**

ISO 9001 Reg 415

**Certified
Product**



WaterMark

AS3498 Lic W208
Standards Australia

Certified to Australian Standard 3498 by Quality Assurance Services. Watermark certification is awarded to products with suitable fittings complying with safety and water contamination standards.

Comparative Energy Consumption tested to The Australian Gas Association requirements of Australian Gas Code AG 102. An energy rating of 5 stars refers to an efficiency of approximately 80%, that is, 80% of gas consumed is converted to useful heat.



- | | |
|-----------------|--|
| <i>ISO 9001</i> | <i>Model for Quality Assurance in design/development, production, installation and servicing, aimed primarily at achieving customer satisfaction by preventing nonconformity at all stages from design through to servicing.</i> |
| <i>ISO 9002</i> | <i>Same as ISO 9001 but excluding design.</i> |
| <i>AS 3498</i> | <i>Authorisation requirements for plumbing products - water heaters and hot-water storage tanks, aimed at ensuring safe, quality products.</i> |
| <i>AG 102</i> | <i>Approval requirements for gas water heaters as set by The Australian Gas Association and Australian Liquefied Petroleum Gas Association Ltd, to ensure proper safety performance and quality levels are achieved.</i> |

© Copyright Rinnai Australia Pty Ltd
ABN 74 005 138 769 - ACN 005 138 769
All rights reserved
May 2000

No portion or part of this manual may be copied without prior permission from Rinnai Australia. Rinnai Australia takes no responsibility for the accuracy or otherwise of information contained in this manual.

Key to Warning Symbols

Failure to comply with the following instructions may result in serious personal injury or damage to the appliance.

Be careful of possible electric shock. Wiring inside this appliance may potentially be at 240 Volts.

Remove the plug from the power source when carrying out any of the following activities.

Read Fault Diagnosis and Wiring Diagram carefully to avoid incorrect wiring.

Do not disassemble. Parts within cannot be exchanged or diagnosed faulty.

Please follow instructions in chapters to ensure safe and appropriate service.

After completing the service and confirming that there are no water or gas leaks or incorrect wiring, test operation of the appliance. After confirming normal operation, explain what was serviced to the customer and operation principles if necessary.

This manual has been compiled by Rinnai Australia Product Services. While many individuals have contributed to this publication, it will be successful only if you - the reader and customer - find it useful. We would like to extend an invitation to users of this manual to make contact with us, as your feedback and suggestions are valuable resources for us to include as improvements. Rinnai are constantly working toward supplying improved appliances as well as information, and specifications may be subject to alteration at any time.

Table of Contents

Glossary of Terms and Symbols	v
1. Introduction	1
2. Features	2
3. Dimensions	3
4. Installation	4
5. Remote Controls	5
6. Safety Devices	7
7. Specification	8
8. Cut-away Diagram	9
9. Schematic Diagram	11
10. Combustion Specification	12
11. Dip Switch Positions	13
12. Water Flows	17
13. Gas Consumption	21
14. Main Components	23
15. Time Charts	26
16. Operation Flow Principle	29
17. Operation Principles	31
18. Error Messages	33
19. Diagnostic Points	34
20. Wiring Diagram	35
21. Fault Diagnosis	36
22. Electrical Component Analysis	45
23. Gas Conversion	49
24. Gas Pressure Setting Procedure	50
25. Dismantling for service	51
26. Exploded Diagram	57
27. Parts List	61

Glossary of Terms and Symbols

This glossary of terms and symbols is provided to assist you in understanding some of the language used throughout this manual.

dB(A)	-	sound pressure level in decibels, “A” range
DC	-	direct current
AC	-	alternating current
WFCD	-	water flow control device
FB	-	feedback information
Hz	-	Hertz
IC	-	integrated circuit
kcal/h	-	kilocalorie per hour
kPa	-	kilopascals
LED	-	light emitting diode
L/min	-	Litres per minute
mA	-	milliamps
MJ/h	-	megajoule per hour
mm	-	millimetres
mmH ₂ O	-	millimetres of water (guage pressure)
NO _x	-	oxides of nitrogen (NO & NO ₂)
OHS	-	overheat switch
PCB	-	printed circuit board
CPU	-	central processing unit
POT	-	potentiometer
rpm	-	revolutions per minute
SV	-	solenoid valve
∅	-	diameter
Δ °C	-	temperature rise above ambient
POV	-	modulating valve
TE	-	thermal efficiency
TH	-	thermistor
T _{IN}	-	temperature of incoming water
T _{OUT}	-	temperature of outgoing water

1. Introduction

The brand name Infinity refers to “Endless Hot Water”. The Infinity series has been developed in response to the growing changes in the lifestyle of consumers, and the increasing diversification and sophistication of demand in the marketplace.

The Infinity series offers reduced cost, advanced safety features, and an option to connect one, two, or three remote control pads.

The Infinity series is delivered with the maximum hot water temperature of 55°C, with or without remote controls connected.

The Heavy Duty 20 is ideally suited for commercial or hydronic situations, as it is possible to obtain a maximum outgoing hot water temperature of 75°C (with remote control connected) or 85°C (without remote control connected) - see page 16 for details on requirements for setting the Heavy Duty 20 to provide 85°C outgoing hot water.

About the Infinity

The front cover of each appliance in the new series is formed from 0.6 mm coated steel, secured to the main box assembly by 4 screws. Seals around the front cover and flue outlet prevent water from entering the appliance.

Air inlets are situated in the front panel. The general layout of components is shown on the cutaway diagram on page 9 to page 10. All components are supported within a box formed from 0.8 mm coated steel.

The heat exchanger occupies the top section of the box, and the burner is situated in a chamber formed from 0.8 mm aluminised steel attached to the bottom of the heat exchanger.

The air for combustion is supplied by a fan which is connected to the burner box by a duct at the left hand side of the appliance.

Gas and water controls are situated at the bottom right of the appliance, directly under the manifold. The products of combustion are expelled from the appliance through a flue outlet situated on the front of the appliance, at the top.

The burner assembly is made up of 18 identical stainless steel bunsen burners, secured by an aluminised steel framework. An aluminium manifold with 18 integrally moulded injectors supplies gas to the burners, and is attached to the lower front cover of the burner box.

There is one thermistor, it is located on the outgoing hot water supply tube, near the outlet of the heater.

2. Features

Installation

The light-weight, slim, and compact form enable easier, improved appearance installations. The remote controls (where fitted) are connected to the appliance by 2-core non-polar cable, ensuring easy wiring and eliminating misconnection problems.

Low Noise Level

Low noise level design enables these appliances to be installed in units, flats, townhouses, and other high density residential areas with little concern about noise disturbances.

Safety

Various safety devices controlled by a micro-computer ensure complete safety. Also, the anti-frost device (where fitted), automatically prevents the water inside the appliance from freezing by using small electrical ceramic heaters connected to the pipework at strategic locations.

Economy

Direct electronic ignition to the main burner eliminates wasteful pilot gas consumption. The combustion fan rpm is proportionally controlled with gas consumption. This maintains high energy efficiency as the gas consumption changes.

Water Supply Control

The water supply capacity varies proportionally from 2.7 L/min to 24 L/min. A suitable volume of hot water can be supplied throughout all seasons by the water flow control device and water flow servo mechanism. The REU-2408 and REU-2008 models will supply up to 21 L/min, and REU-2424 model will supply up to 24L/min, (maximum unmixed), controlled by an automatic electro-mechanical water flow device. The REU-2007 model will supply up to 15 L/min at water temperature of 15°C, (maximum unmixed), controlled by a mechanical water flow control device. See page 17 for precise details on water flow.

Water Temperature Control

With a remote control connected, the hot water control range is between 37°C and 55°C (in 13 steps). With or without a remote control connected the outgoing hot water temperature can be fixed to a maximum of 40°C, 43°C, 50°C, 55°C, 60°C, 65°C or 75°C and in the case of the Heavy Duty 20 with no remote, 85°C can be reached. This means that the Infinity Series can be set to comply with various State laws on temperature control in homes, child care centres, and elderly care centres. The maximum temperature selectable on the bath remote control is 50°C (this is a safety feature).

Over Temperature Protection

All Infinity models incorporate a device to prevent the hot water temperature exceeding the pre-set temperature by more than 3°C.

Temperature Locks

With the remote control(s) connected, the pre-set water temperature can only be altered between 37°C and 43°C while the hot water is flowing. This helps to avoid inadvertently increasing the temperature to a hazardous level whilst someone is in the shower. While the water is flowing, the remote control(s) can be turned off, but not on again.

3. Dimensions

Note: All dimensions are in mm.

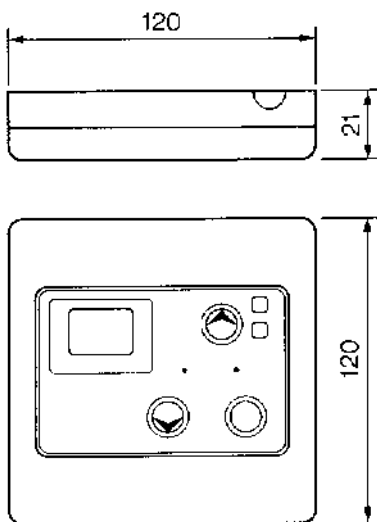
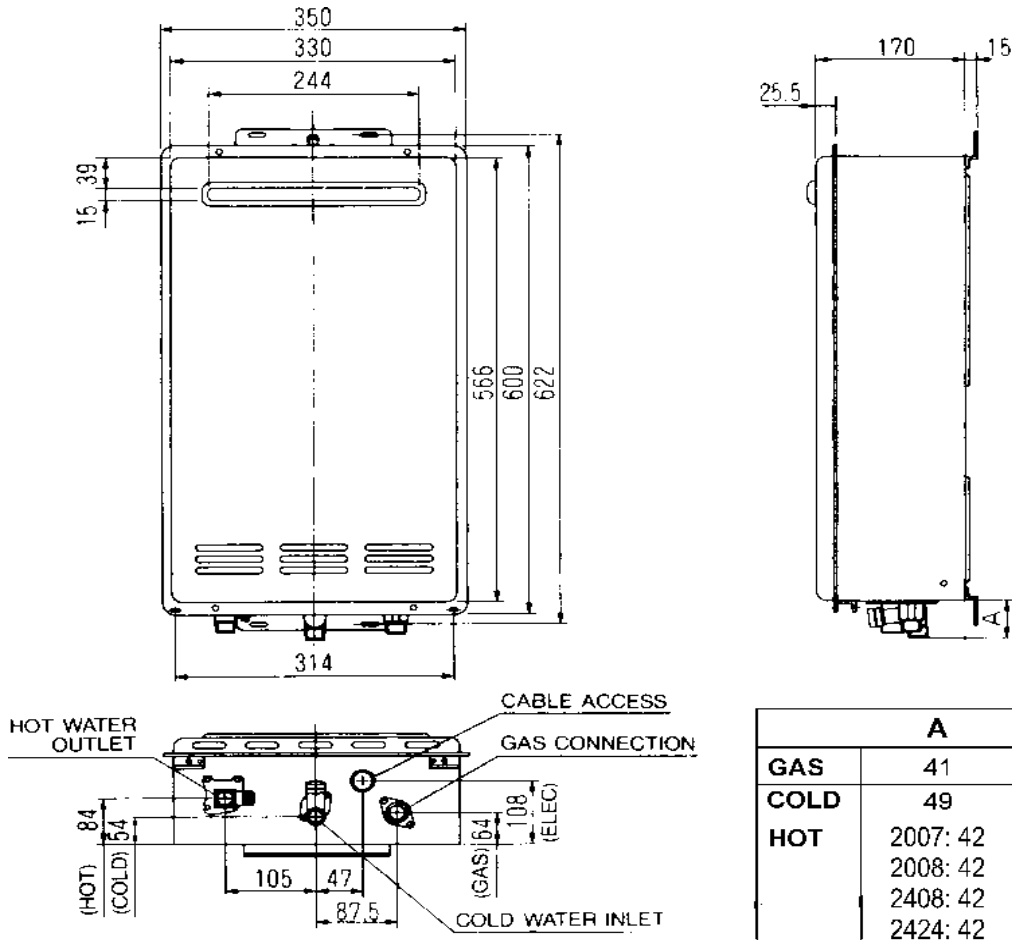

Kitchen Control
MC-33-3A

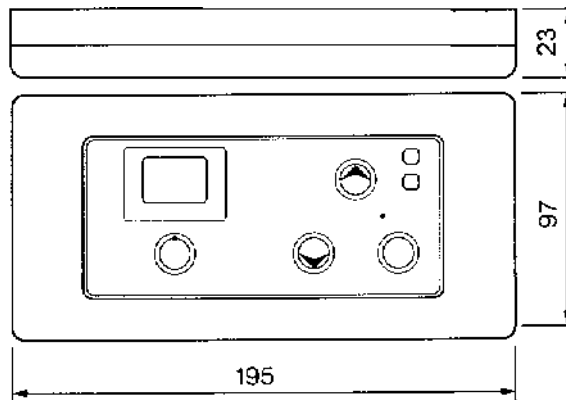

Bath Control
BC-45-3A
BSC-45-3A

4. Installation

Note: All dimensions are in mm. Pipework will vary in each installation.

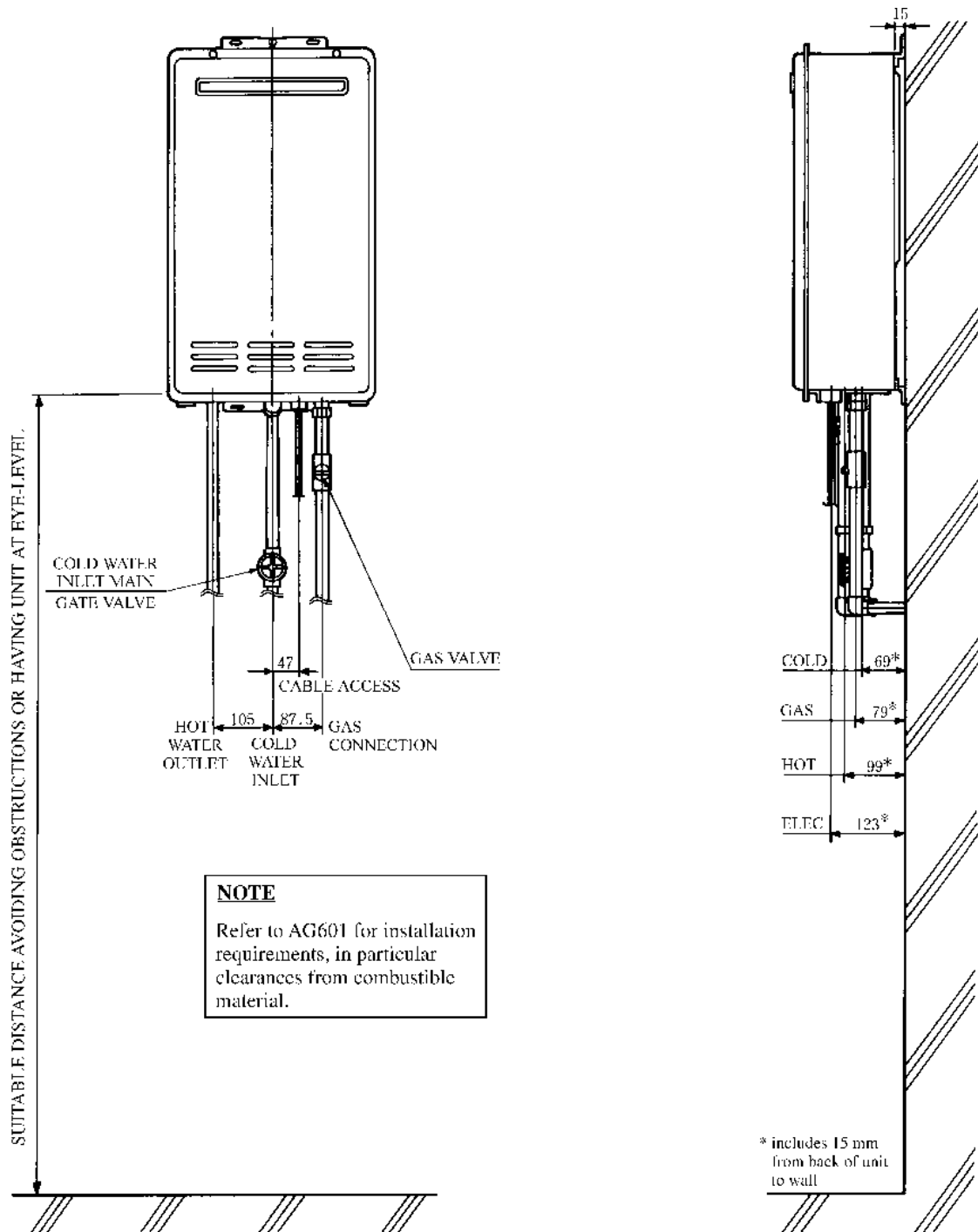

5. Remote Controls

The MC-33-3A, BC-45-3A, and BSC-45-3A remote controls were specifically designed for use with the Infinity water heaters manufactured from March 1997.

Features include:

- Colour coordination to allow immediate recognition of the temperature “hotter” and “cooler” buttons.
- Larger LED display.
- Water temperature adjustment only in the range of 37°C to 43°C whilst hot water is flowing.
- Different temperatures can be stored in the memory of each individual remote control.

- Enhanced communication system between the remote controls, allowing priority temperature selection at each remote control.

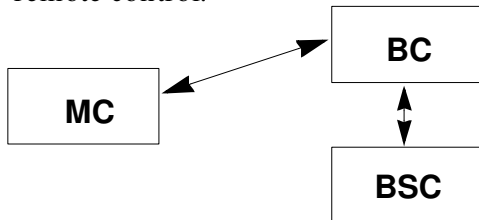

- A third remote control identified by model number BSC-45-3A is available for use in a second bathroom or ensuite. Contact Rinnai for further details.

Kitchen Remote Control

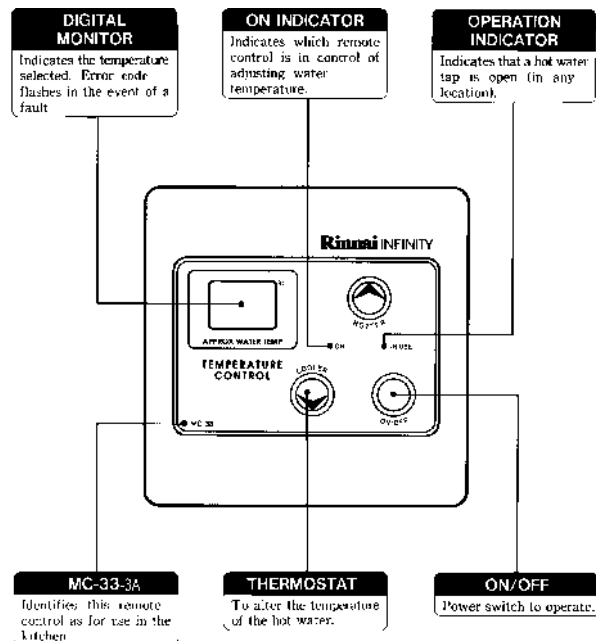

Bathroom Remote Control

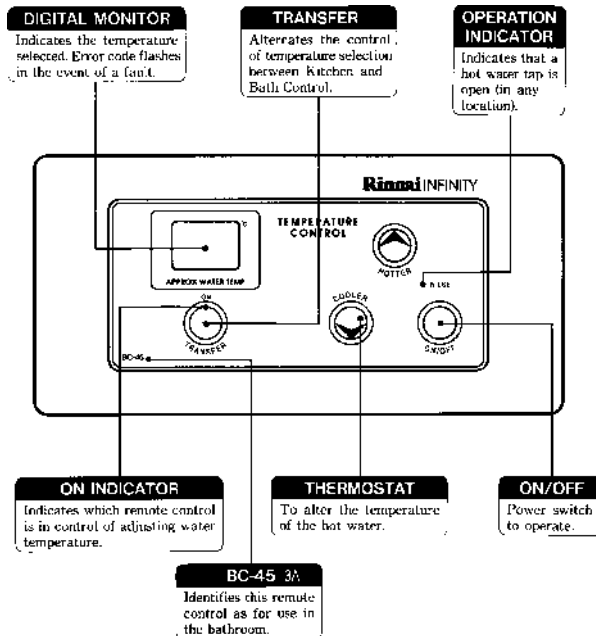

Suggested Connection Methods

There must be at least one cable from any remote control connecting with the Infinity water heater.

Connections

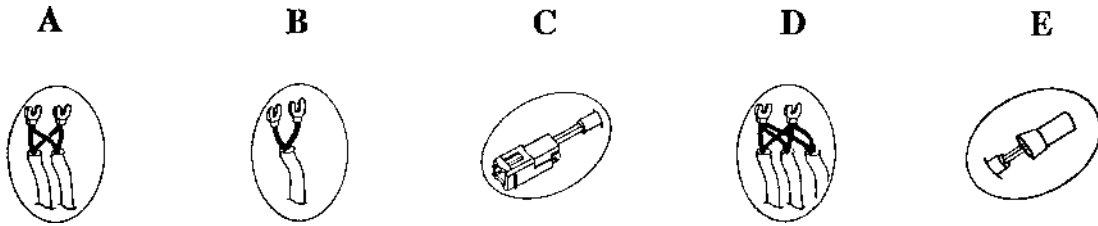

The following diagrams show methods of connection.

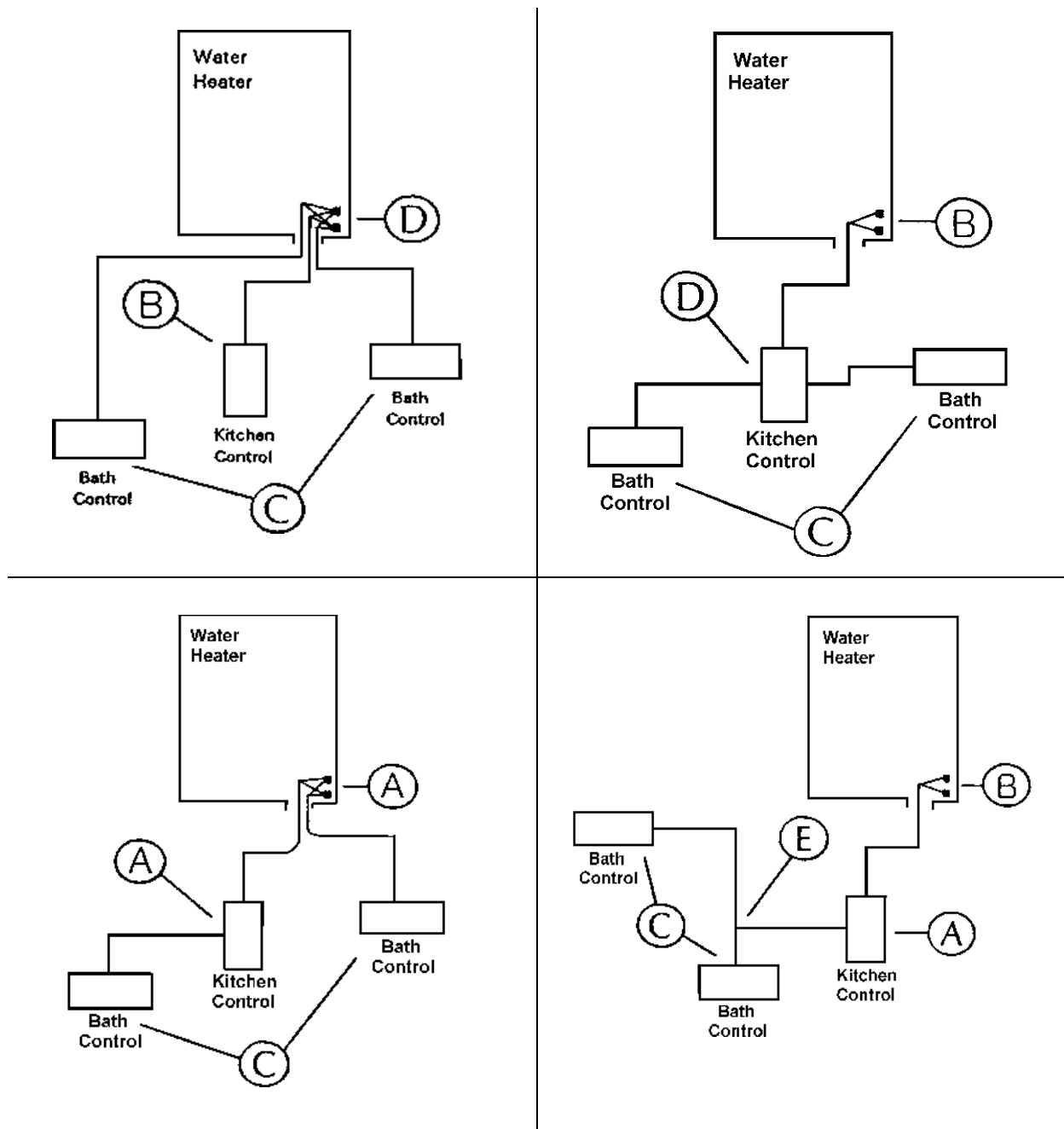

6. Safety Devices

Flame Failure

Situated to the right of the burner at the front, the flame rod monitors combustion, preventing any discharge of gas to the burner if there is no flame, by sending a signal to the PCB which in turn isolates the gas.

Over Heat Protection Device

Also referred to as an Over Heat Switch. This device is fitted to a bend section at the inlet to the heat exchanger. If the flame remains on the burner after the tap is closed, and the water temperature inside the heat exchanger reaches 97° C, an DC 12 volt bi-metal cut-off switch isolates the gas to the solenoids.

No Water

Should the incoming water flow become restricted or stop, then the water flow sensor will cease to send a magnetic pulse signal to the PCB, in turn isolating the flow of gas to the burner.

Thermal Fuse

Wrapped around the entire surface of the heat exchanger, if the heat exchanger burns out, or the temperature outside it reaches 129° C, the thermal fuse melts, breaking the electronic circuit. Current to the gas solenoid valve circuit is cut, and combustion stops, shutting down the unit.

Pressure Relief Valve

This spring and valve seating type valve located on the hot water outlet will release the built up pressure if the pressure inside the heat exchanger reaches 2100 kPa until 1500 kPa is maintained.

Combustion Fan Revolution Check

The combustion fan rpm are continually monitored by a magnetic pulse counter connected to the PCB. If the fan revolutions deviate from the speed required for complete combustion, a signal is sent to the PCB and the revolutions adjusted accordingly. (If not the unit shuts down)

Automatic Frost Protection (Only on units specified K)

When the outdoor temperature drops and the temperature inside the appliance below 3.5° C, the frost sensing device is activated, and the anti-frost heaters prevent the water in the appliance from freezing. These anti-frost heaters remain ON until the temperature inside the appliance rises to 11.5° C. There are 5 x 16 Watt anti-frost heaters located at various points in the main water flow area of the appliance. The anti-frost protection device will prevent freezing down to -20° C in a no wind situation, and -15° C in a windy situation.

3° C Over Temperature Cut-Off

The temperature of the outgoing hot water is constantly monitored by the water temperature thermistor located near the outlet of the appliance. If the outgoing water temperature reaches 3° C above the preset temperature, the burner will automatically go out. The burner will only ignite again once the outgoing hot water temperature falls below the preset temperature.

7. Specification

Type of appliance	Temperature controlled continuous flow gas hot water system.			
Operation	With or without remote controls, mounted in kitchen, bathroom, or ensuite.			
Exhaust system	Forced combustion			
Rinnai model No.	REU-2007	REU-2008	REU-2408	REU-2424
Maximum gas rate	160 MJ/h	160 MJ/h	188 MJ/h	188 MJ/h
Hot water capacity, unmixed	2.7 to 11.5 L/min	2.7 to 20 L/min	2.7 to 20 L/min	2.7 to 24 L/min
Hot water capacity, mixed (25 °C rise)	2.7 to 20 L/min	2.7 to 20 L/min	2.7 to 24 L/min	2.7 to 24 L/min
Default temperature (without remote) Set using switches on PCB	40,43,50,55,60,65,75 °C			40,43,50,55,60,65, 75 °C and 85 °C
Maximum temperature ceilings (remote connected)	40, 43, 50, 55, 60, 65, 75 °C (set by combination of switches on PCB)			
Temperature range (with remote)	37 to 55 °C in 13 steps			
Approved gas types	Natural; Propane; (New Zealand only - LPG)			
Installation	Externally mounted.			
Dimensions	Width - 350 mm. Height - 600 mm. Depth- 170 mm.			
Weight	18 kilograms.			
Efficiency rating	80%			
Noise level	49 dB(A)			
Connections	Gas supply- R			

8. Cut-away Diagram

For REU-2008, 2408, 2424

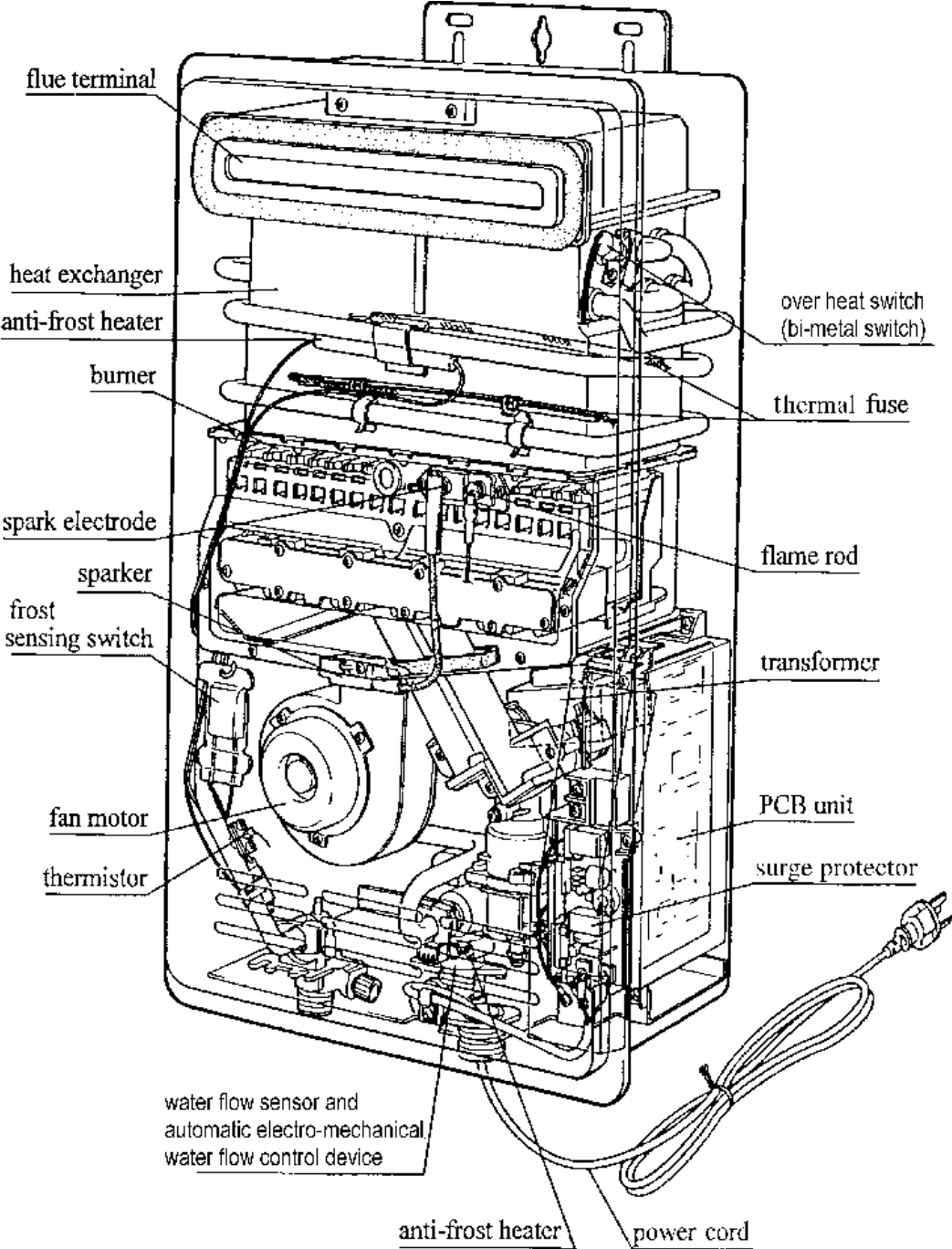

For REU-2007

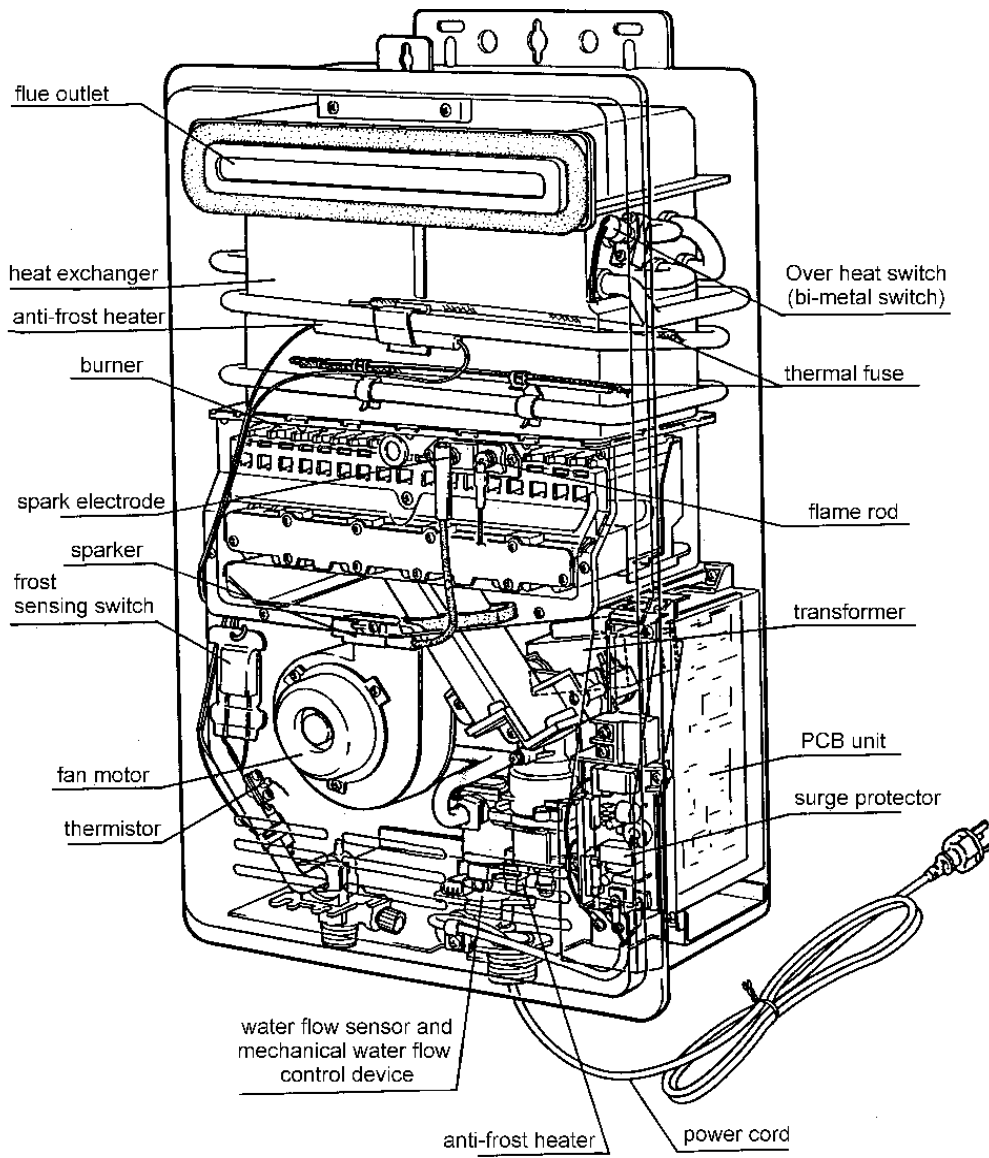

9. Schematic Diagram

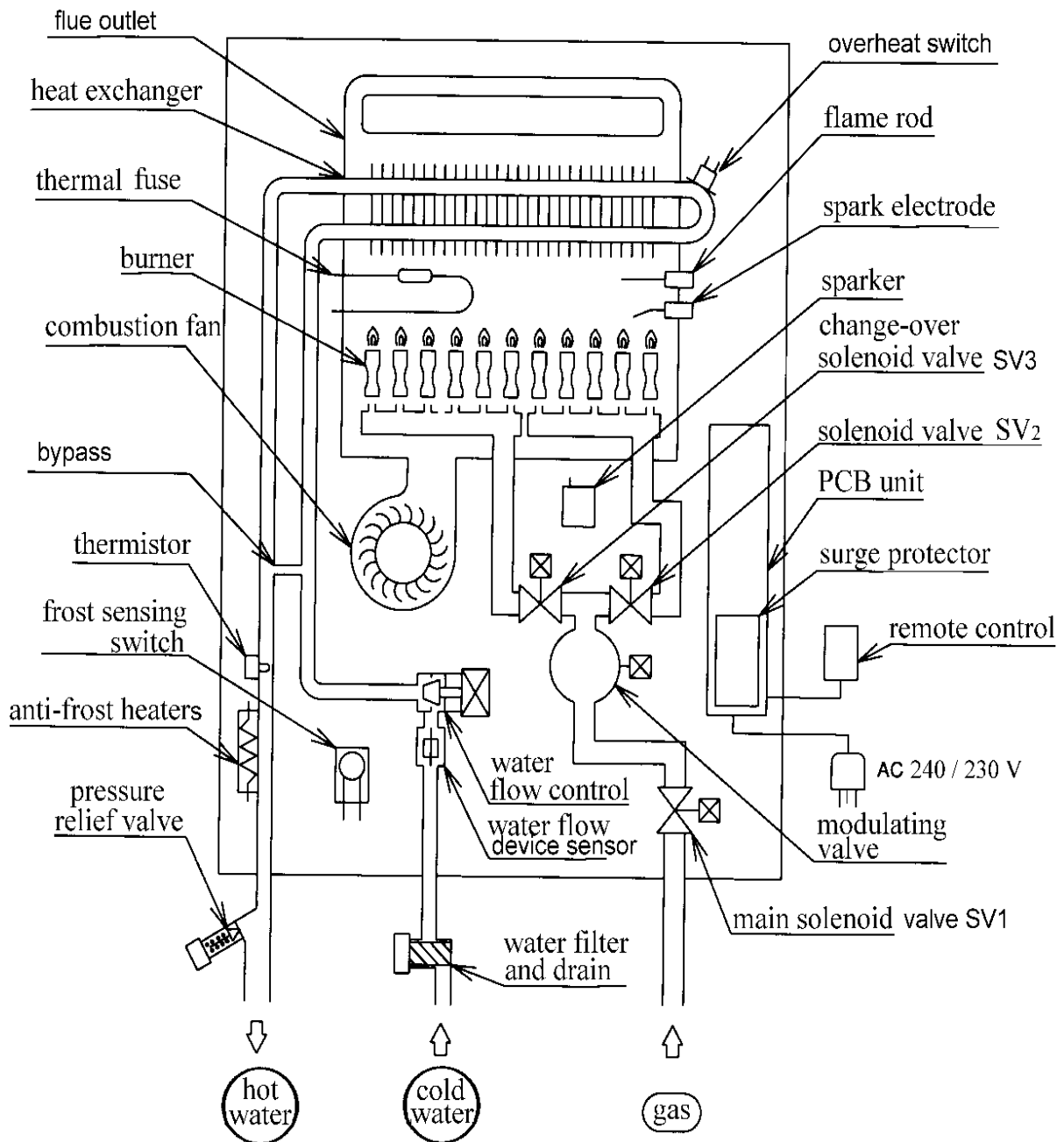

10. Combustion Specification

Note: Where LPG details are not specified in brackets, Propane and LPG details are common.

				2007/2008	2408	2424
Input	NG/Propane LPG #	HI	MJ/h	160	188 (180)	188 (180)
		LO		21	21	21
Gas Consumption	NG/Propane LPG #	HI	kW	44.2	52.3 (50)	52.3 (50)
		LO		5.93	5.93	5.93
Integral Injector size (18)	NG		mm	∅ 1.7	∅ 1.7	∅ 1.7
	Propane/LPG #			∅ 1.0	∅ 1.0	∅ 1.0
Damper* (1 piece)	NG			NIL	NIL	NIL
	Propane/LPG #			A	A	A
Pressure	NG	HI	kPa	0.65	0.90	0.90
		LO		0.08	0.08	0.08
	Propane/LPG #	HI	kPa	1.60 (1.51)	2.26 (1.90)	2.26 (1.90)
		LO		0.17 (0.15)	0.17 (0.15)	0.17 (0.15)
Burner type				NG/ Propane	NG/ Propane	NG/ Propane
Dip Switch positions				Refer to page 13		
Maximum Capacity						
Modulating Valve (mA)	NG		mA	120	147	147
	Propane			189	229	229
	LPG #			181	208	208
Combustion Fan (Hz)	NG		Hz	220	264	264
	Propane/LPG #			242	272	272
Minimum Capacity						
Modulating Valve (mA)	NG		mA	20	20	20
	Propane/LPG #			20	20	20
Combustion Fan (Hz)	NG		Hz	96	96	96
	Propane/LPG #			87	87	87
Slow Ignition						
Modulating Valve (mA)	NG		mA	88	91	91
	Propane			144	152	152
	LPG #			140	140	140
Fan (Hz)	NG		Hz	160	160	160
	Propane/LPG #			160	160	160

The REU-2008, 2408, 2424 Series are not approved for use on Town Gas

* Indicated by an imprint on actual component.

LPG - New Zealand only.

11. Dip Switch Positions



Please do not adjust the DIP Switch Positions before reading this information

The dip switches are provided so that the water heater can be set to different operating configurations. In some instances such as nursing homes or even domestic situations, it may be necessary to limit the temperature of the hot water coming from the units.

The set-up configuration for the water heater differs depending on:

- Gas type
- Maximum water flow select
- Temperature limiting requirements
- Alternate type

DIP Switches explained

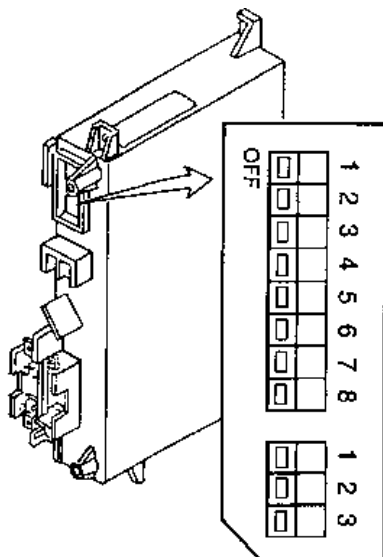

Top switch settings 1 ~ 8

- 1 : Gas type (used only during conversion)
- 2 : To select maximum water flow volume
- 3 to 5: To select fixed temperature without remote
- 6 to 8: To select maximum temperature with remote connected

4 to 8 for modified PCB (see settings). To select the temperature with or without remote connected.

Note: PCB were modified in April & May 1999 to accommodate the temperature flow switch to operate without control (see for settings). Dip switch settings for temperature with or without controls have changed since modifications. Please check serial number prior to adjusting.

Bottom switch settings 1 ~ 3

- 1 : Factory use (To select the capacity of appliance)
- 2 & 3: Combustion control

The Infinity model series are delivered with maximum hot water temperature limited to 55° C, however the maximum temperature of hot water can be fixed to 40° C, 43° C, 50° C, 55° C, 60° C, 65° C, or 75° C.

A further maximum temperature of 85° C can be achieved only on the Heavy Duty 20 without a remote control connected, refer page 16 for specific details.

1. Gas Type

Only alter gas type positions when converting. For conversion instructions refer to page 49.

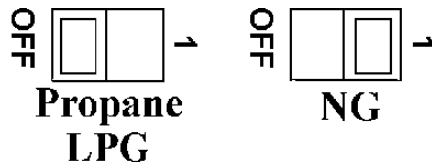

2. Maximum Water Flow Select

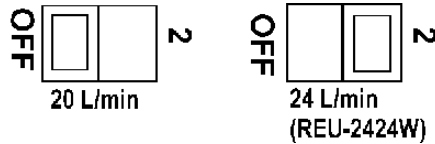

3. Temperature Limiting

There are different positions, depending on the temperature limit required and whether the remote controls are connected or not.

Dip Switch Settings for Pre Modified PCB

a. Fixed hot water temperature “without” remote connected

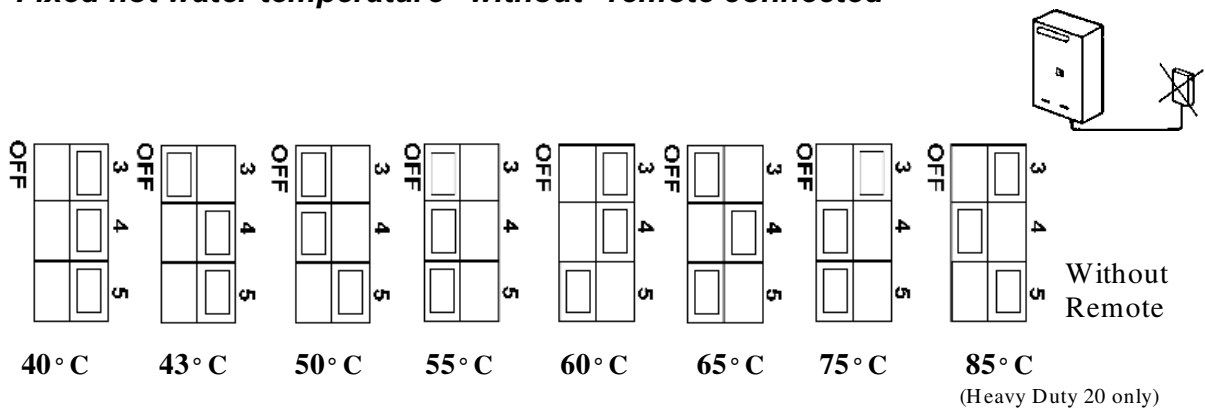

b. Upper limit hot water temperature “with” remote connected

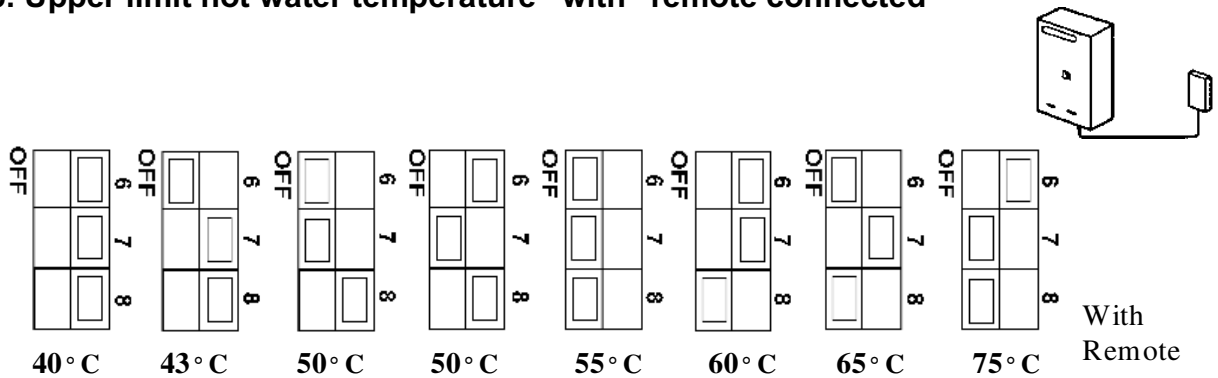

If dip switches 6, 7 & 8 are set to any of the positions shown above and the remotes become disconnected, the outgoing water temperature will automatically default to the temperature set on switches 3, 4 & 5 (as shown above).

We recommend that switches 3, 4 & 5 be set to the OFF position to ensure a 55° C default setting. This will provide a safe default temperature if the remote controls become disconnected.

Note: Check to see whether the by-pass tube has not been squeezed or cut-off. If so, the unit is not suitable for use in the 55° C default mode.

Dip Switch Settings for modified PCB

No.	Model	Carried out form	Gas Type	Serial No.
1	REU-2408W-A-NC	06.05.99 01.05.99	LP NG	99.05.00481~ 99.05.002691~
2	REU-2408W-AK-NC	19.05.99 14.05.99	LP NG	99.05.000061~ 99.05.000221~
3	REU-2424W-A-NC	01.05.99	LP	99.05.000362~
4	REU-2424W-AK-NC	01.05.99 10.05.99 01.05.99	NG LP NG	99.05.002931~ 99.05.000141~ 99.05.000421~
5	REU-2008W-A-NC	01.05.99 22.04.99	LP NG	99.05.000261~ 99.04.001420~
6	REU-2008W-AK-NC	30.04.99 01.05.99	LP NG	99.05.000046~ 99.05.000086~

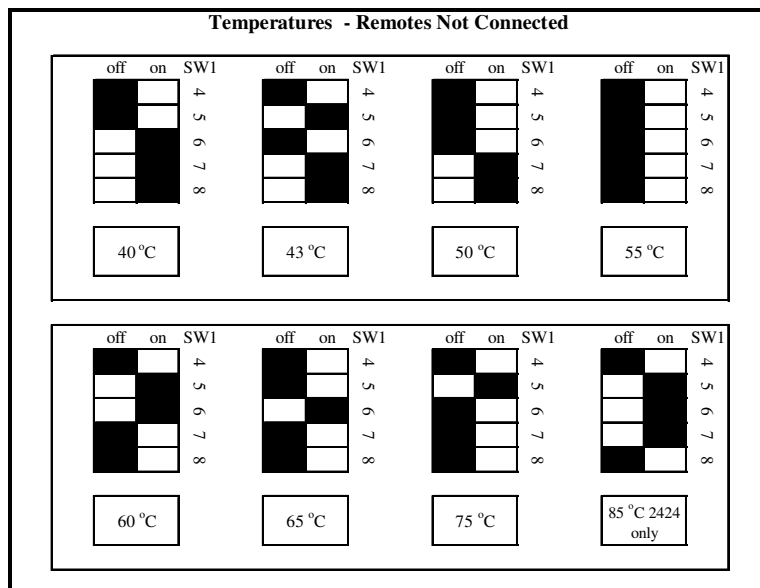
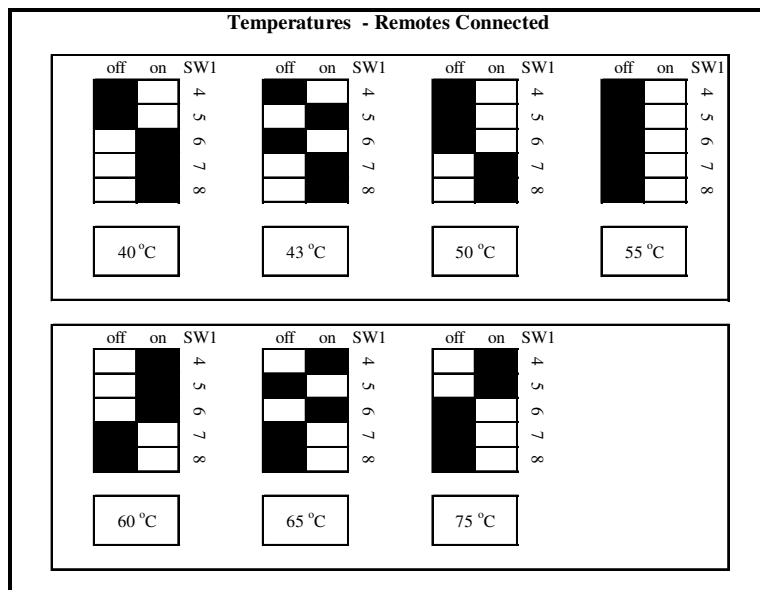

- Note:
- The black squares indicate the position of switches.
 - It will be noted that some dip switch configurations are the same for a given temperature whether controllers are connected or not. These similarities are not mistakes.
 - If remote controls are connected and the maximum pre-set temperature is above 55°C, in the event that the remote control becomes faulty or disconnected, the maximum preset temperature will revert to 55°C.

c. 85° C Outgoing hot water temperature (Heavy Duty 20 only without remote)



85° C outgoing hot water can be achieved by placing dip switches No.3 and No. 5 to the ON position, cutting and then sealing the by-pass tube to completely restrict the flow of water through it and disconnecting the remote controls.

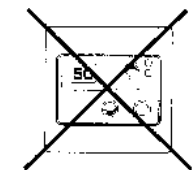

Disconnect remote
Step 1

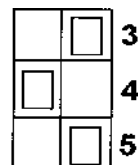

3 & 5 ON
Step 2

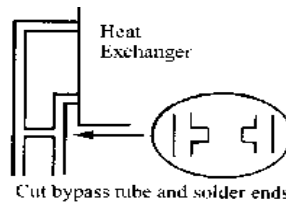

Step 3

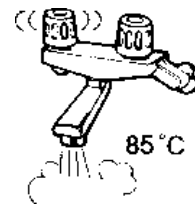

The by-pass must be sealed if the 85° C setting is selected in single or multi-point installations.

Note: The remote control(s), if connected will override the 85° C setting, and maximum hot water temperature will revert back to 75° C. Condensation above the burner may occur at temperatures of 55° C or lower when the bypass is restricted.

Modified PCB

85° C outgoing hot water can be achieved by placing dip switches No. 5, No. 6 and No.7 to the ON position, cutting and then sealing the by-pass tube to completely restrict the flow of water through it and disconnecting the remote controls.

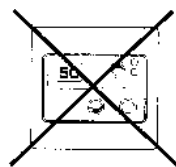

Disconnect remote
Step 1

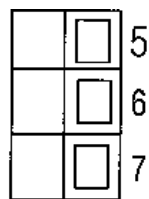

5, 6 & 7 ON
Step 2

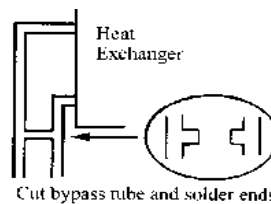

Step 3

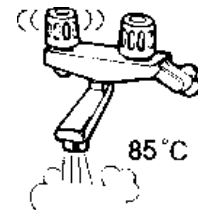

The by-pass must be sealed if the 85° C setting is selected is selected in single or multi-point installation.

Note: The remote control(s), if connected will override the 85° C setting, and maximum hot water temperature will revert back to 75° C. Condensation above the burner may occur at temperature of 55° C or lower when the bypass is restricted.

12. Water Flows

A simple calculation of the water flow rate, in litres per minute, can be made using the charts on the next page, or simply using the formula provided below. The charts on the following pages indicate the water flow from the Infinity at various combinations of incoming water temperatures, and the selected temperature at the remote control.

How to read the charts:

The vertical plane indicates the selected temperature at the remote, and the horizontal plane indicates the flow of water in litres per minute. Remote control range is between 37°C and 75°C, therefore the water flow charts only show the temperatures in that range. The temperature rise is the difference between the temperature of the incoming water and the selected temperature at the remote controls.

Select the appropriate chart depending on the incoming water temperature. Draw a horizontal line across the graph from the selected temperature at the remote until it intersects the curve. At this point draw the line in the vertical direction. The water flow is indicated where the line intersects the bottom of the chart.

How to calculate water flows:

The following information is an outline of the formula required to measure accurately the flow rate in litres per minute, as well as being the base for the charts on the next page. The most useful way in which this formula can be utilised, is to calculate the water flow rate where there is maximum gas input of 160MJ/h or 188MJ/h depending on the model.

$$\text{Formula: } IN \times TE = (T_{OUT} - T_{IN}) \times 60 \times Q$$

Where:

- T_{IN} = Incoming water temperature.
- T_{OUT} = Outgoing water temperature as selected at the remote.
- IN = Gas input[#].
- TE = Thermal efficiency*.
- Q = Water flow in litres per minute.

This is the maximum gas input converted from MJ/h into kilocalories. As 1 kilocalorie raises the temperature of 1 litre of water by 1 degree centigrade, the method of calculation is to multiply the input in MJ/h by 239.

* Thermal efficiency may be in the range of 78% to 90%, depending on the temperature rise and water flow. For the purpose of the following calculation we have assumed an efficiency of 80%.

Example Data	Calculation
$T_{IN} = 15^{\circ}C$ $T_{OUT} = 60^{\circ}C$ $IN = 45000kcal/h$ $TE = 80\%$ $Q = \text{Water flow in Litres per minute}$	$IN \times TE = (T_{OUT} - T_{IN}) \times 60 \times Q$ $4500 \times 0.8 = (60 - 15) \times 60 \times Q$ $36000 = 45 \times 60 \times Q$ $\frac{36000}{45} = 60 \times Q$ $800 = 60 \times Q$ $\frac{800}{60} = Q$ 13.3 L/min

Unmixed Water Flows for the REU-2007

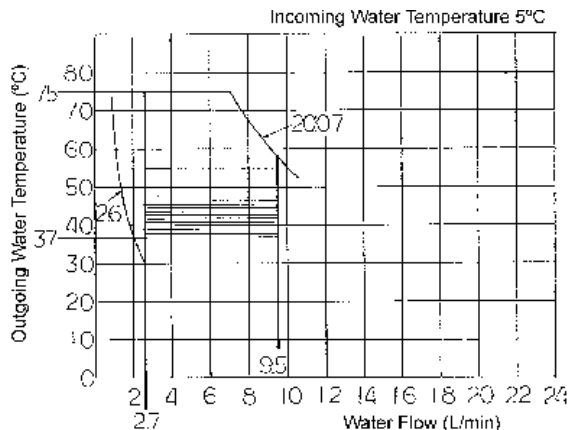

The chart opposite indicates that the water flow rate of the REU-2007 will, at a preset temperature of 50°C and an *incoming water temperature of 5°C*, be 9.5 litres per minute.

The chart opposite indicates that the water flow rate of the REU-2007 will, at a preset temperature of 50°C and an *incoming water temperature of 15°C*, be 11.5 litres per minute.

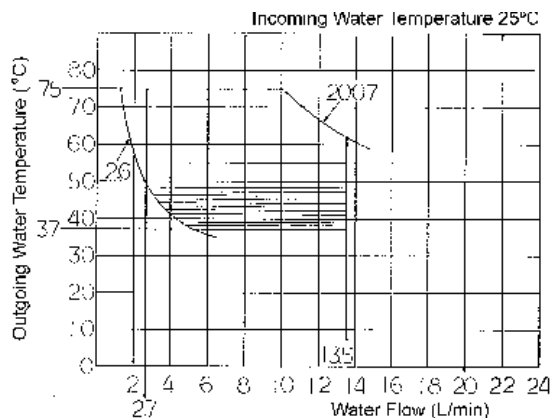
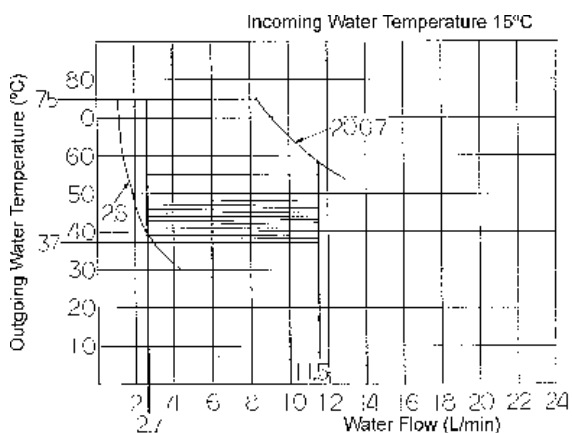

The chart opposite indicates that the water flow rate of the REU-2007 will, at a preset temperature of 50°C and an *incoming water temperature of 25°C*, be 13.5 litres per minute.

Mixed Water Flows for the REU-2007

Output water temp.	Incoming +15°C	Incoming +25°C	Incoming +30°C	Incoming +35°C	Incoming +45°C	Incoming +55°C
Output water vol.	with mixing 33 L/min	with mixing 20 L/min	with mixing 16.7 L/min	14.5 L/min	11 L/min	9 L/min

Unmixed Water Flows for the REU-2008, REU-2408

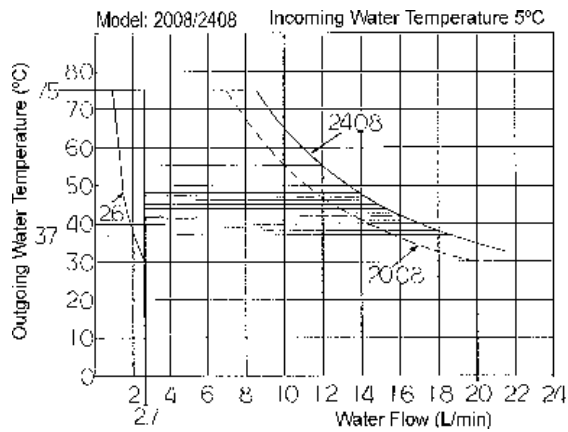

The chart opposite indicates that the water flow rate of the REU-2008/2408 will, at a preset temperature of 50°C and an *incoming water temperature of 5° C*, IS 13 litres per minute.

The chart opposite indicates that the water flow rate of the REU-2008/2408 will, at a preset temperature of 50°C and an *incoming water temperature of 15° C*, is 17 litres per minute.

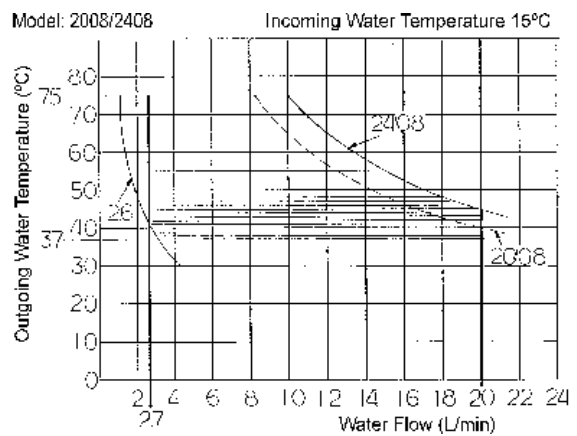

The chart opposite indicates that the water flow rate of the REU-2008/2408 will, at a preset temperature of 50°C and an *incoming water temperature of 25° C*, is 20 litres per minute.

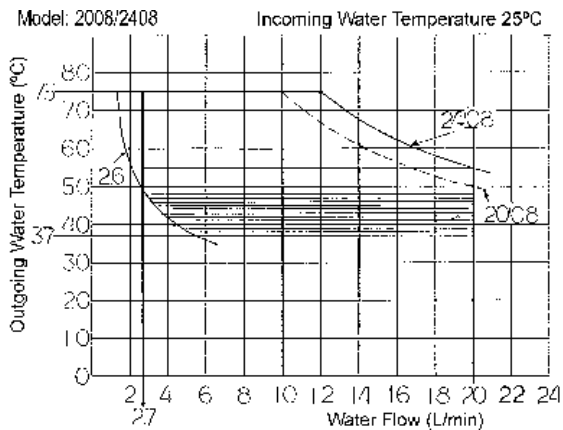

Unmixed Water Flows for the REU-2424

The chart opposite indicates that the water flow rate of the REU-2424 will, at a preset temperature of 50°C and an *incoming water temperature of 5°C*, is 14 litres per minute.

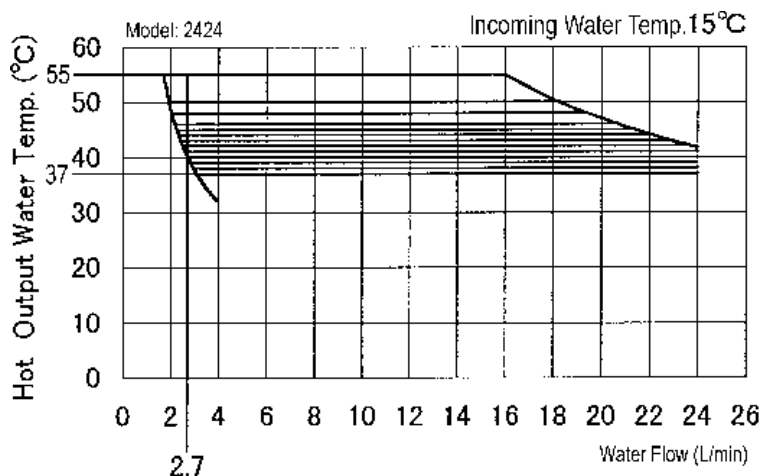
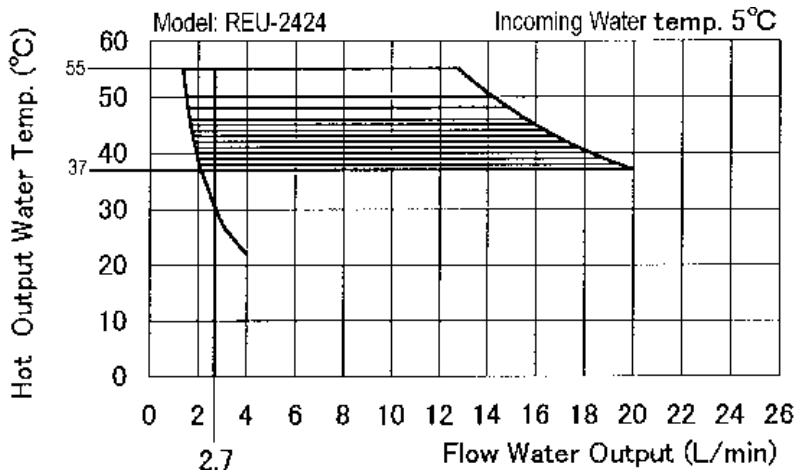

The chart opposite indicates that the water flow rate of the REU-2424 will, at a preset temperature of 50°C and an *incoming water temperature of 15°C*, be 18 litres per minute.

The chart opposite indicates that the water flow rate of the REU-2424 will, at a preset temperature of 50°C and an *incoming water temperature of 25°C*, be 24 litres per minute.

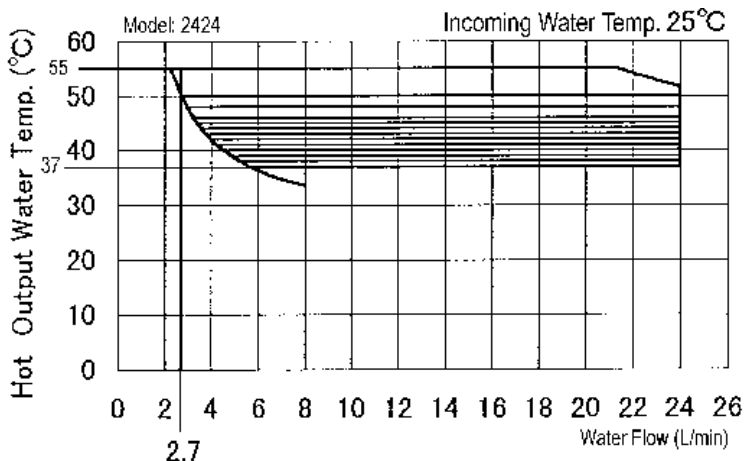

Mixed Water Flows for the REU-2008, REU-2408 AND REU-2424

Output water temp.	Incoming +15°C	Incoming +25°C	Incoming +30°C	Incoming +35°C	Incoming +45°C	Incoming +55°C
Output water vol.	with mixing 40 L/min	with mixing 24 L/min	with mixing 18 L/min	17.1 L/min	13.3 L/min	10.9 L/min

13. Gas Consumption

The most common unit used to calculate the energy required to heat water is the kilocalorie.

If the full gas rate is not required to provide the required water temperature rise, [i.e. - when the temperature selected at the remote controls is lower, or the incoming water temperature is higher]; the amount of gas that the water heater is going to use to carry out a specific heating task will change proportionally to these variables. The actual gas rate is based upon the following calculation.

Calculating Gas Input

Formula:
$$\frac{(T_{OUT}-T_{IN}) \times Q \times 60}{239 \times TE} = IN \text{ MJ/h}$$

See previous page for an explanation of TIN, TOUT, IN, TE and Q.

Example data	Calculation
T _{IN} =15°C	$\frac{(60 - 15) \times 10 \times 60}{239 \times 0.8} = IN \text{ MJ/h}$
T _{OUT} =60°C	$\frac{45 \times 10 \times 60}{239 \times 0.8} = IN \text{ MJ/h}$
IN=Gas input in MJ/h	$\frac{27000 \text{ (Kcal/h)}}{191.2} = IN \text{ MJ/h}$
TE=80%	
Q=10 L/min	141 MJ/h=IN

The Infinity is able to control both the water and gas flows. The gas input varies depending on the water flow and incoming and outgoing water temperatures. The chart on the following page is an approximate guide to the gas input according to the various temperature rises and water flows.

To calculate the approximate gas input, first select the appropriate curve representing the water flow in litres/minute [L/min.]. From the base line draw a vertical line at the point where the required temperature rise in degrees Celsius (°C) is indicated. This can be calculated by subtracting the incoming water temperature from the selected temperature on the remote control. Draw a horizontal line from the point where the vertical line intersects the curve. The point where the horizontal line intersects the left hand vertical line (Gas Input), shows the approximate gas input in MJ/h.

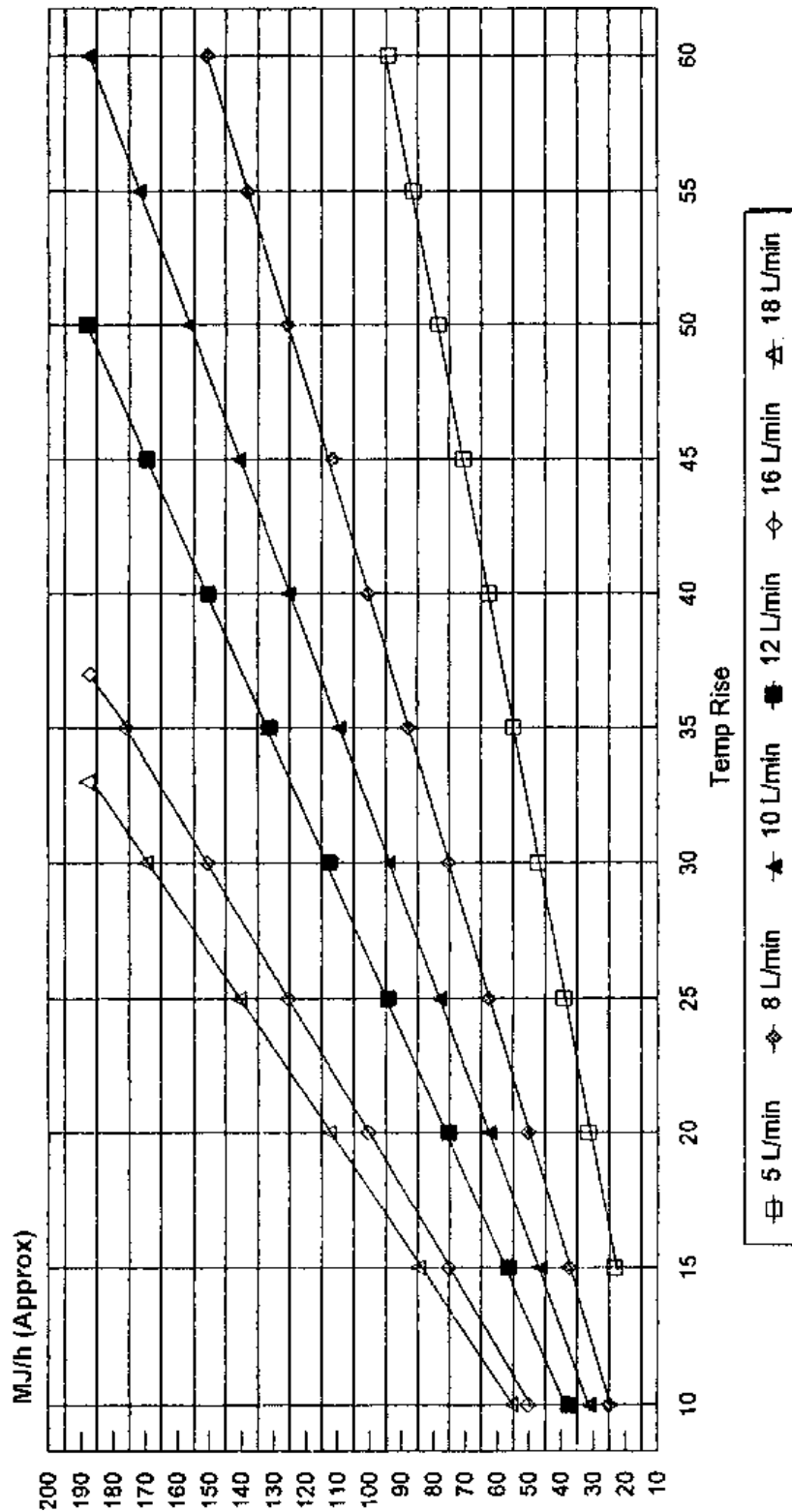

This chart is an approximate guide to the gas input according to various temperature rises and water flows. See previous page, last paragraph for the explanation on how to calculate approximate gas consumption in MJ/h.

14. Main Components

1. Mechanical Water Regulator

Rinnai's unique water regulator mechanism ensures the hot water is maintained with no noticeable change to the desired temperature during use, even if water pressure drops due to another tap being turned on and increasing the demand.

The following graphs show the performance of the water regulator. On the chart for the 2007, the top line shows the performance when the incoming water is 25°C, and the lower line when it is 5°C.

The following graphs show that the maximum flow is approximately 20 L/min for the 2008/2408, 24 L/min for the 2424 or 13.5 L/min for the 2007. This maximum flow is reached at 200 kPa inlet pressure respectively.

Note: Although the 2008 and 2408 will operate at very low water pressures, maximum performance is not reached unless the incoming pressure is 200 kPa or more. The 2007 requires 340 kPa to reach maximum performance.

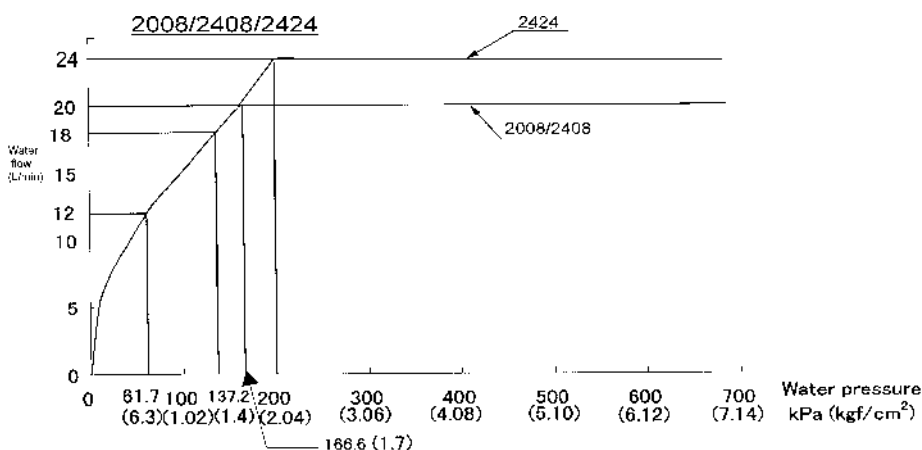
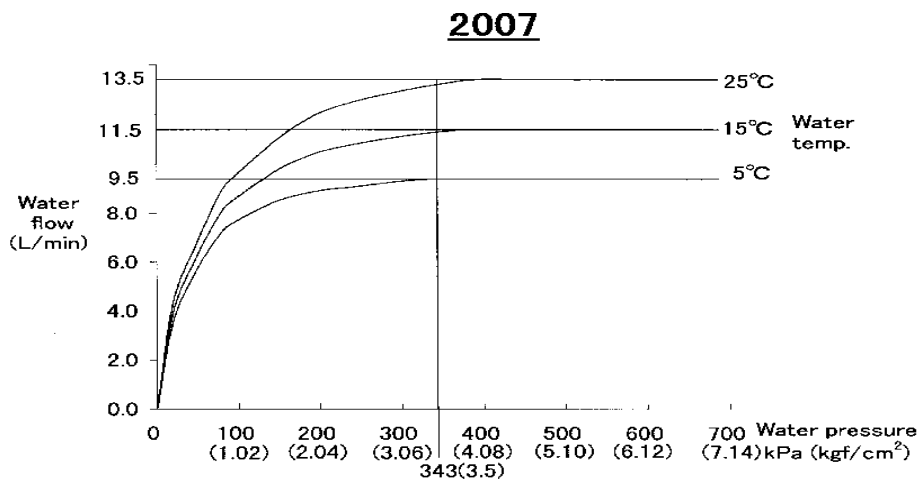

2. Preset Bypass

A preset volume of cold water is mixed with water heated in the heat exchanger.

3. Burner

The burner assembly is made up of 18 identical stainless steel bunsen burners, secured by an aluminised steel framework. An aluminium manifold with 18 integral injectors supplies gas to the burners, and is attached to the front lower cover of the burner box. Changeover Solenoid Valve

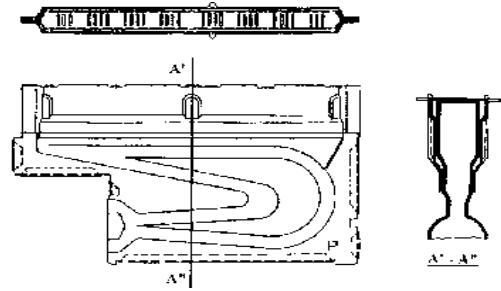

4. Changeover Solenoid Valve

The changeover solenoid increases the flexibility of the regulator/modulating valve by supplying gas to the right hand side of the burner only, [up to 40% input] or both sides of the burner, [40% input] + [40 - 100%] through the tandem manifold.

5. Combustion Fan

Air for combustion is supplied by a centrifugal fan driven by a DC motor. After a pre-purge period of 0.2 seconds, the fan speed is controlled by the PCB to provide the correct volume of air for combustion. The calculation for the fan speed is based upon incoming water temperature, water flow and the temperature selected on the remote controls.

The actual speed of the motor is continuously monitored by a magnetic pulse sensor.

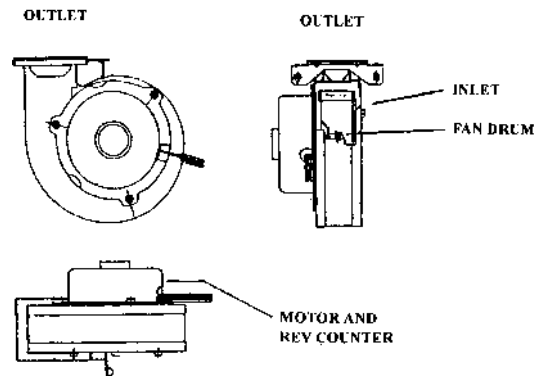

This sensor emits 4 pulses per rotation of the fan. This is the fan feedback or confirmation data processed by the PCB and used for 2 operations.

1. The fan speed is constantly correctly to provide optimum combustion conditions.
2. To determine the opening degree of the modulating gas valve, so that the gas rate always matches the volume of air for combustion, as well as the input required to heat the water.

The reason for controlling the opening degree of the modulating gas valve based upon data from the combustion fan is that the gas valve is able to react much more quickly to a change in control signal than the combustion fan. Controlling the gas valve based upon data from the combustion fan means that combustion remains satisfactory, even if there are sudden changes in input conditions.

6.1 Water Flow Sensor and Water Flow Control device: REU-2008/2408/2424

Water flow is detected by a turbine/magnetic pulse generating device. Water flows through the turbine/magnetic sensor providing information to the PCB by generating a pre-determined number of pulses in proportion to the water flow. These pulses are counted by the PCB - no pulse indicates no water flow. The frequency of the magnetic pulses increases as the water flow increases, this enables the PCB to calculate the exact water flow, and determine the water flow in litres/minute. As soon as the required water flow is detected, the PCB activates the combustion fan. The combustion fan speed is monitored by a magnetic pulse sensor. The output from this sensor is processed by the PCB which opens the gas modulating valve to a degree proportional to the fan speed. See above for further details on the combustion fan.

The water flow control consists of a plug and barrel valve which is rotated by a motor to increase or decrease the volume of water passing through the heat exchanger.

REU-2008, REU-2408 and REU-2424 have an automatic water flow control device.

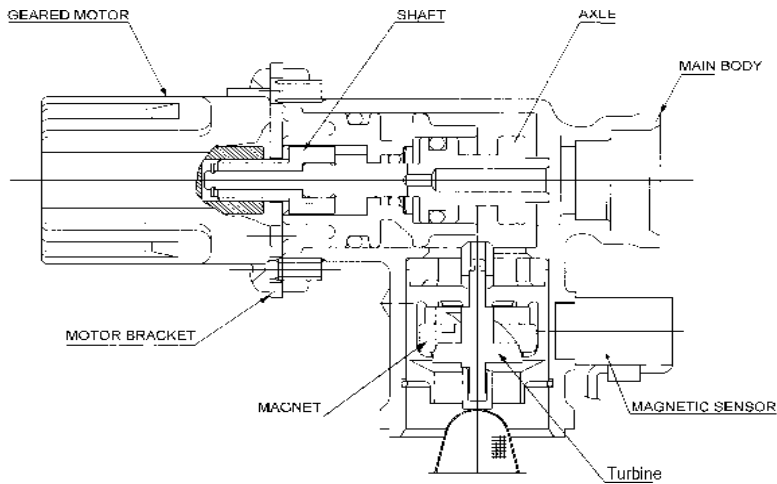

6.2 Water Flow Sensor and Water Flow Control Device: REU-2007

The REU-2007 has a mechanical water flow control device which includes the water flow sensor and stabilises water flow during changes in water pressure. It also helps to prevent the water flow from exceeding the maximum capacity of the water heater. With the water flowing, the impeller (magnetised) rotates clockwise and this is detected by the magnetic sensor. The PCB calculates water flow based on the rpm signal (which is proportional to the water flow) and, determines whether to ignite or extinguish the flame.

A position memory alloy spring in the mechanical water flow control device made from a metal known as NiTi Alloy alters its spring tension according to the incoming water temperature.

In summer, incoming water temperature are generally warmer and the spring tension becomes greater. When the tension is greater, the gap in areas A increases and more water flows through the valve.

In Winter, incoming water temperatures are cooler and the spring tension becomes less. When the tension is reduced, the gap in areas A decreases and less water flows through the valve.

The spring's thermal heat capacity is very low, responding to temperature changes and altering tension in about 1 second. The spring is capable of responding to changes in the range of 5° C to 25° C.

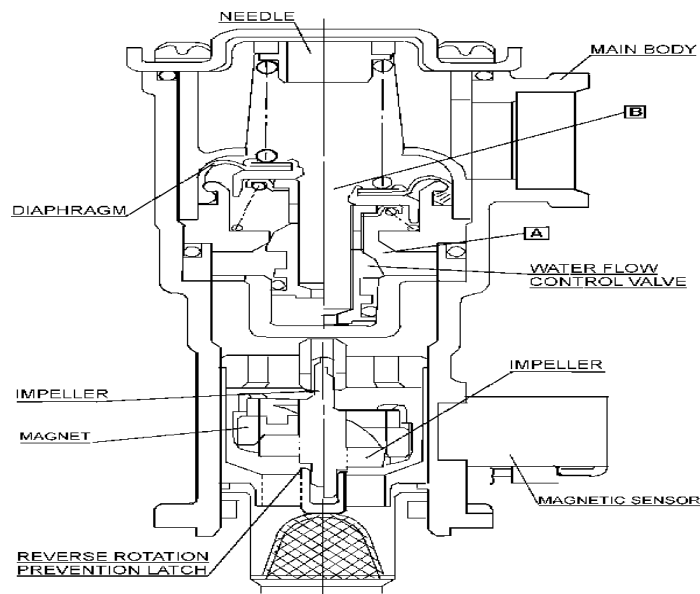

15. Time Charts

REU-2008/2408

Normal Combustion Sequence

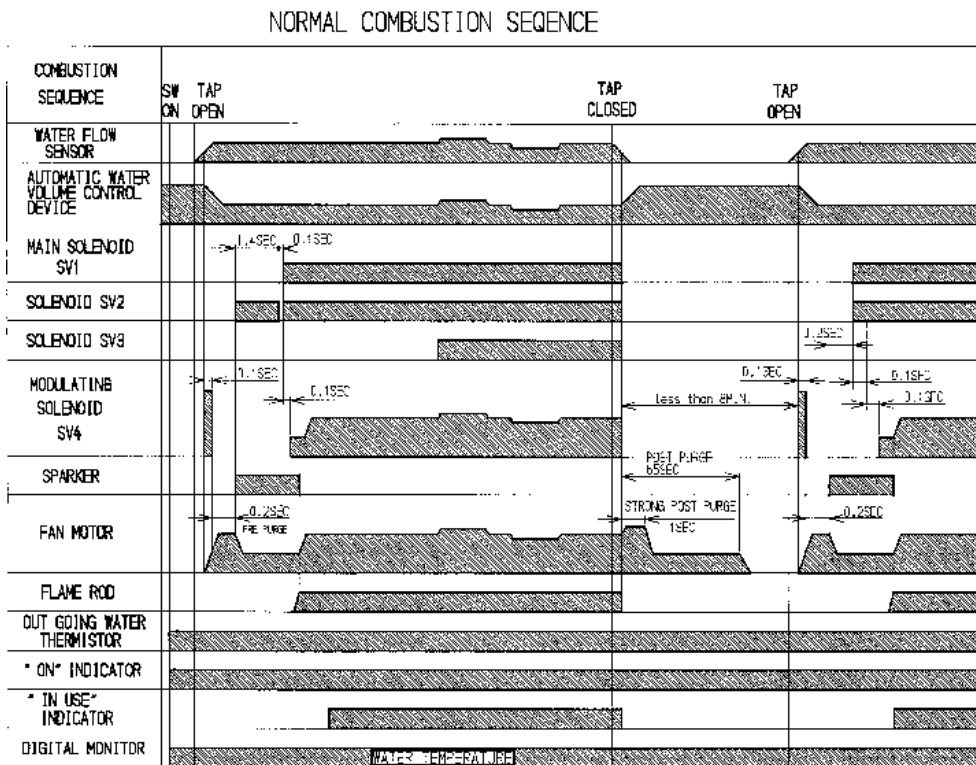

Error Sequence (Ignition / Flame Failure)

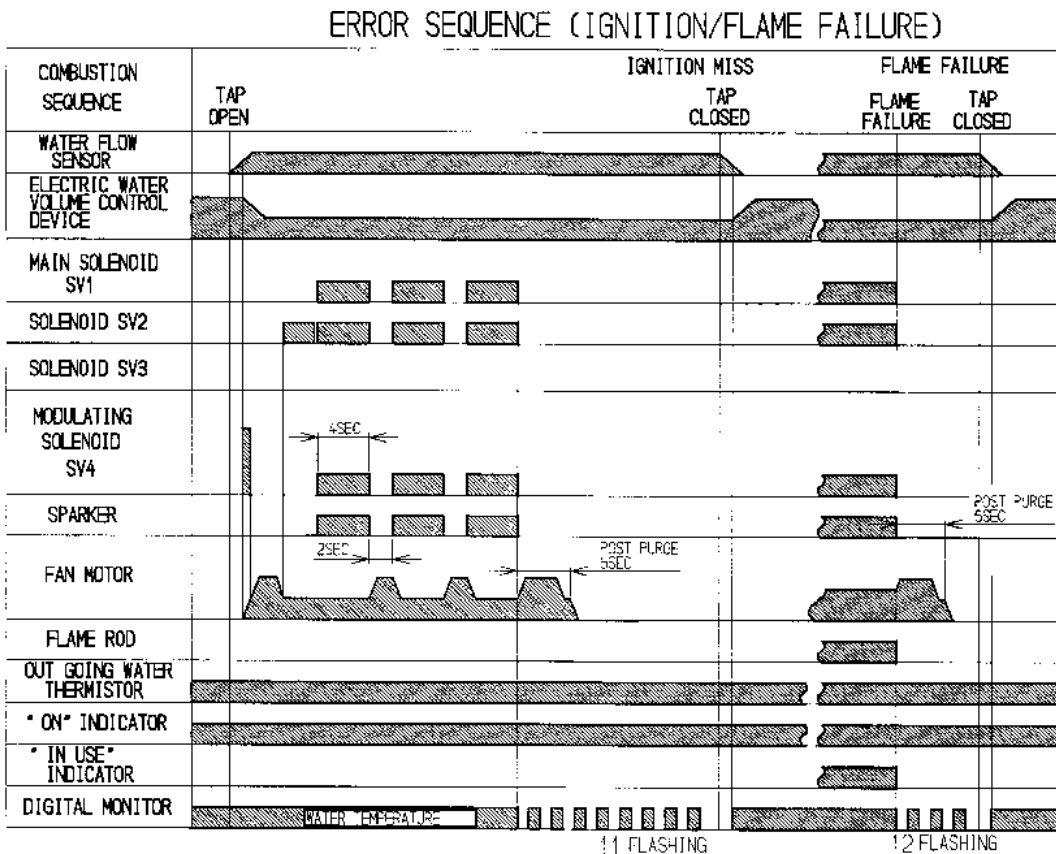

Pre-purge Defect Sequence

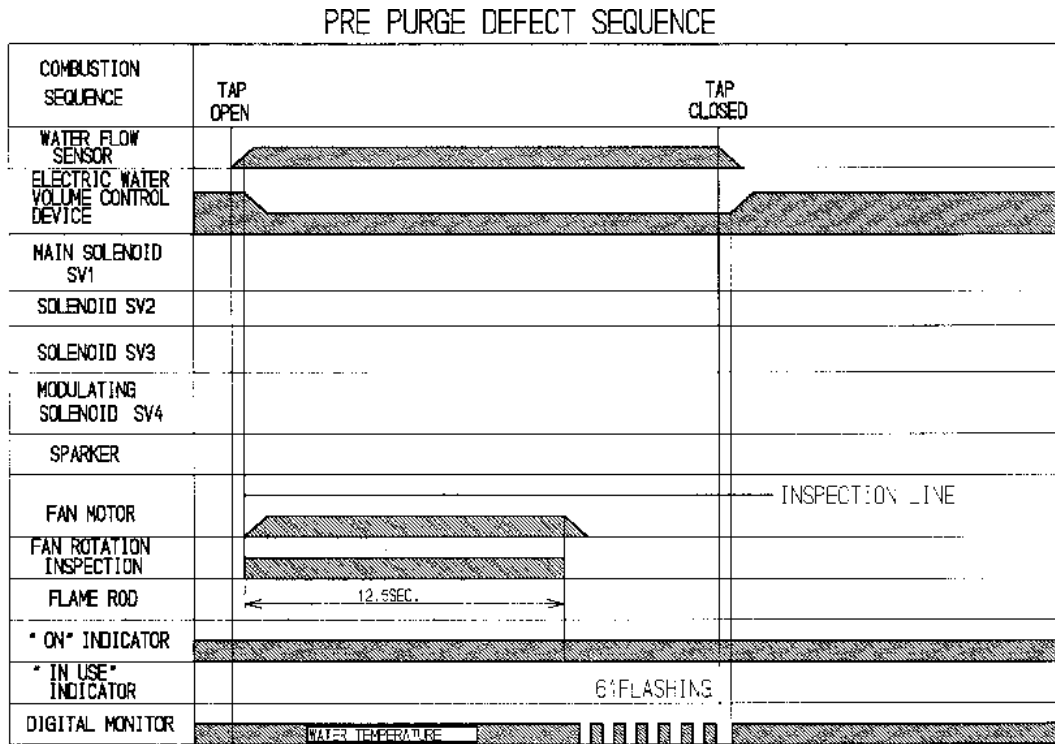

REU-2007

Normal Combustion Sequence

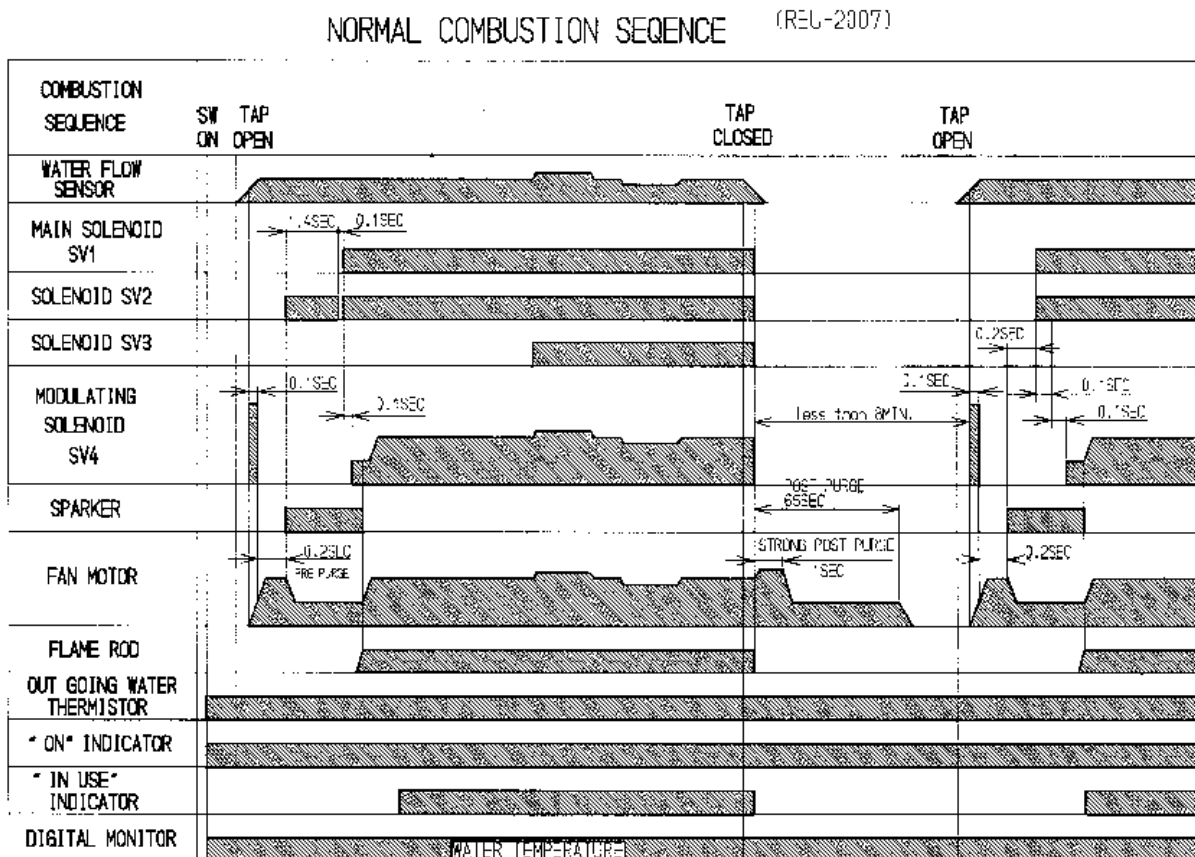

Error Sequence (Ignition / Flame Failure)

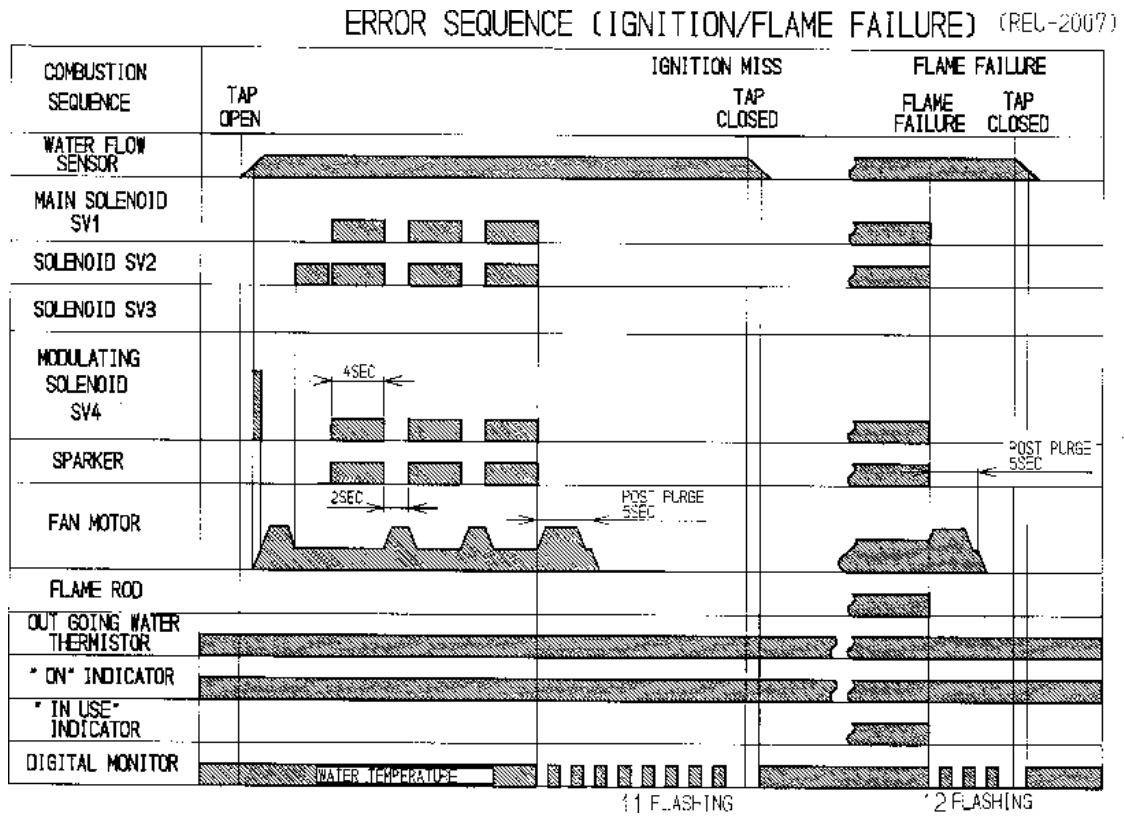

Pre Purge Defect Sequence

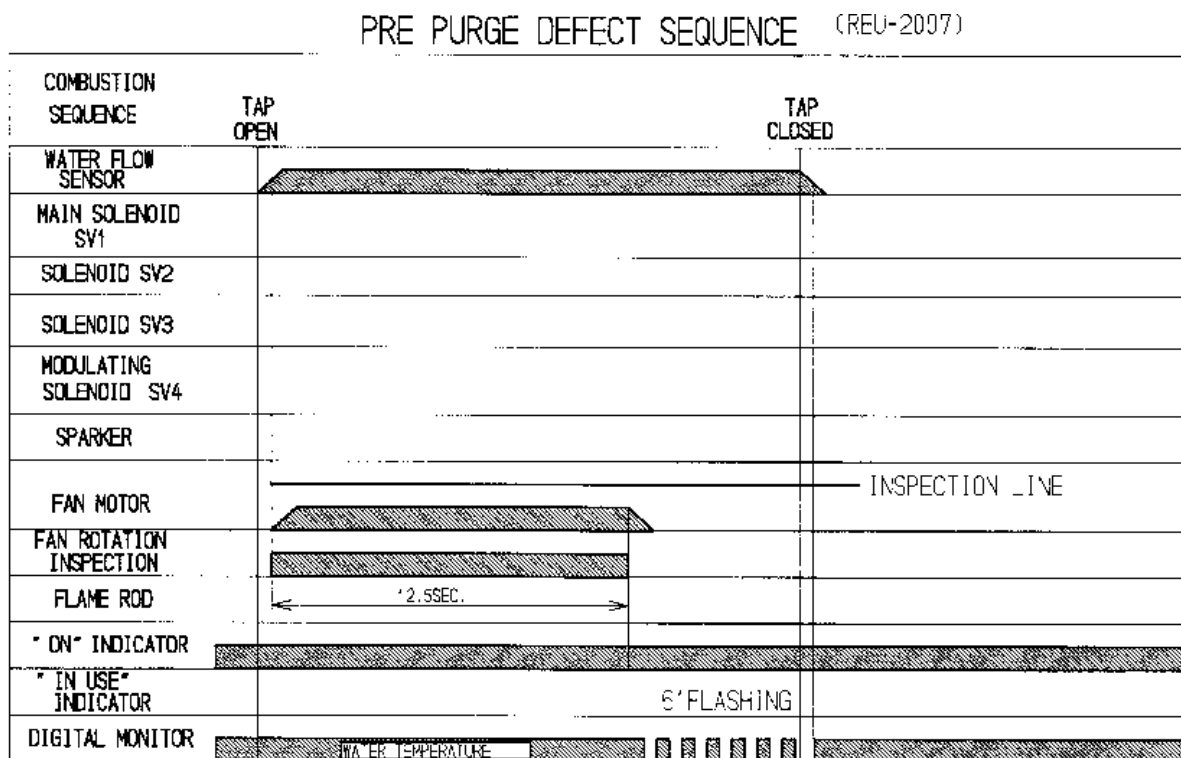

16. Operation Flow Principle

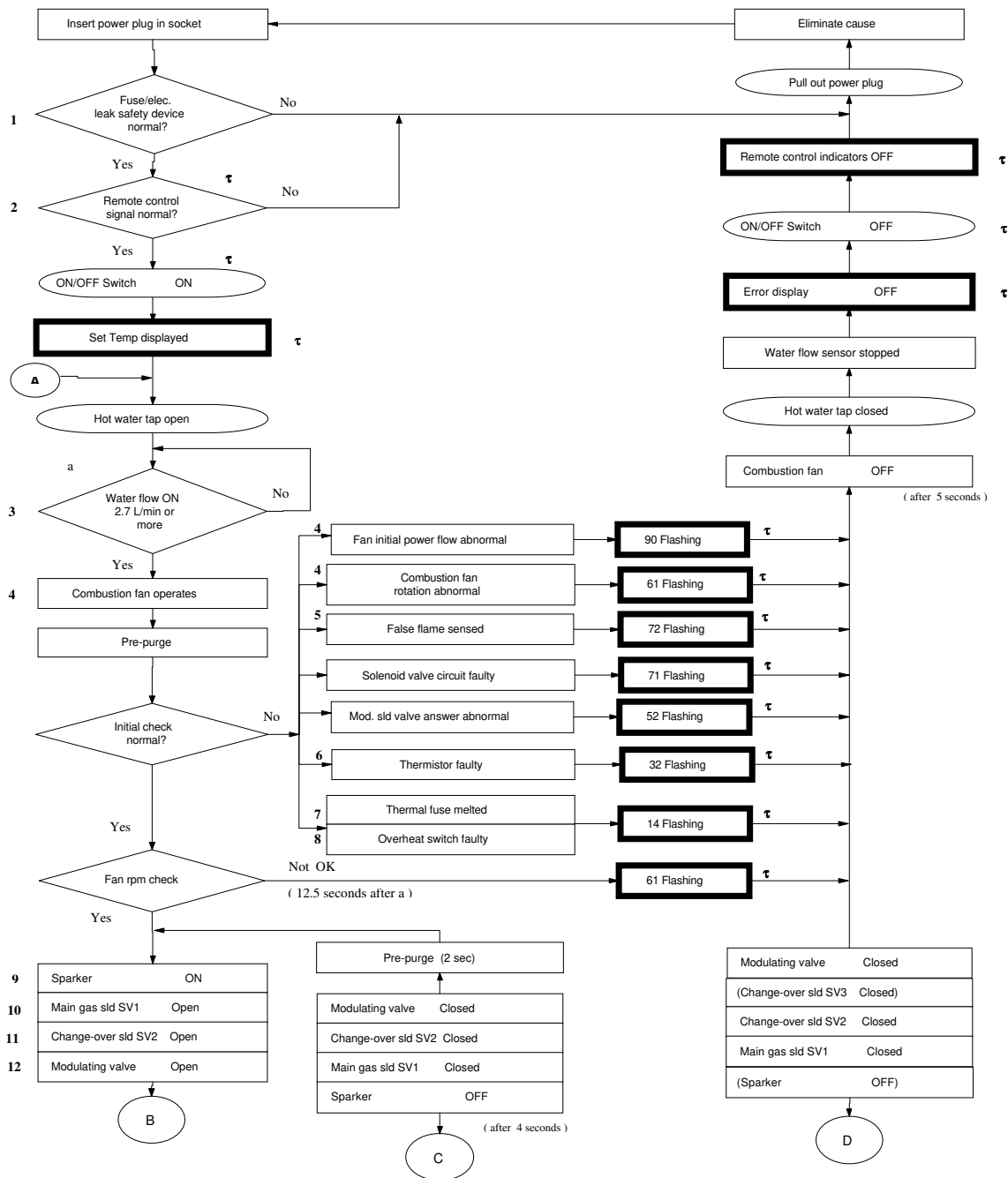

τ Only applicable when remote control is connected

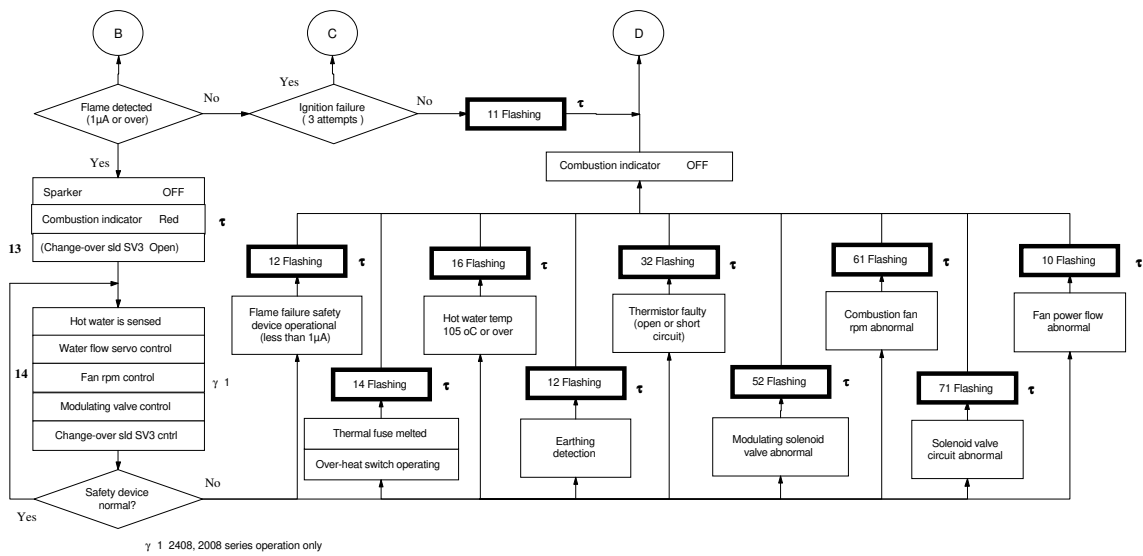

TURN OFF

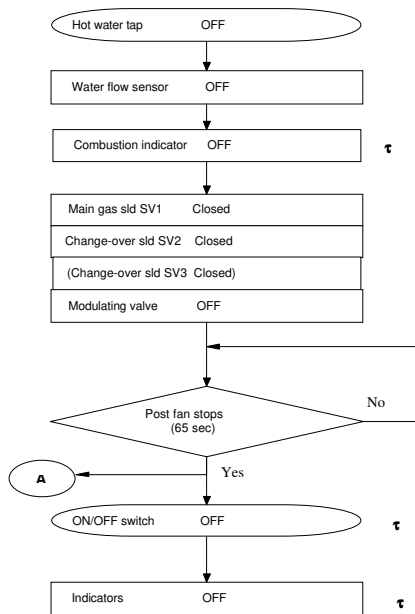

17. Operation Principles

The preset temperature is selected at one of the remote controls (where fitted). Where no remote control is fitted, the default temperature is 40° C, 43° C, 50° C, 55° C, 60° C, 65° C, 75° C or 85° C (Heavy Duty only) depending on the position of dip switch numbers 3 to 6 (see page 13).

When the unit is first plugged into 240 Volts, the PCB assumes an incoming water temperature of 25° C, this prevents the appliance starting on HIGH, and producing very hot water the first time it is used.

The data used to determine the outgoing water temperature initially is incoming water flow, and the remote control pre-set temperature.

From the incoming water flow and remote control pre-set temperature data, the CPU is able to determine a suitable gas rate to kick the appliance off, once a hot water tap opens.

This calculation of temperature rise and water flow is called simulation feed-forward.

The water heater calculates incoming water temperature by subtracting the theoretical temperature rise from the outgoing hot water temperature, to establish the correct gas flow.

When a hot water tap is opened, water begins to flow through the appliance. The turbine in the water flow sensor begins to revolve. The revolution speed is proportional to the water flow. A sensor located inside the device relays information in the form of magnetic pulses to the main PCB to determine whether or not water is flowing, and also, the volume of water flowing. When a pre-determined water flow is sensed, the ignition sequence begins.

The combustion fan pre-purges the combustion chamber. A rev counter on the combustion fan indicates the fan rpm to the main PCB. Once the pre-purge cycle is completed, the PCB controls the fan rpm by varying the DC voltage to the fan motor. This maintains the correct air/gas ratio throughout the time the water heater is in use, to ensure good combustion.

The gas is ignited by direct electronic spark and the flame is sensed by the flame rod. The opening degree of the modulating valve is determined by the combustion fan speed.

The changeover valve directs gas to one side or both sides of the burner. At the point where the changeover valve opens or closes, the modulating valve is instantly re-adjusted by the PCB to compensate for the change in the number of burners in use. From the information provided by the water flow sensor and the water temperature thermistor, the PCB determines how much gas is required to heat the water to the temperature selected on the remote control.

The PCB is programmed to provide the maximum volume of water possible at a given temperature rise. As the water flow from the tap is increased, the PCB increases the gas and air flow to the burner.

In the case of the 2008 and 2408, once the maximum gas rate is reached the PCB begins to control the water flow through the appliance in order to maintain the preset temperature. This is achieved by the PCB turning the valve within the water flow control device by means of a stepping motor.

The water flow control device operates at high water flows and/or high temperature rises. When the temperature rise is low, or the water flow is restricted by the hot water tap, then the device may not be required to operate. [See section on “Main Components” on page 20, for clarification].

There is no direct connection between the mechanical water flow control device with water flow sensor and the PCB, therefore, there could be occasions when the input required to heat the water exceeds the capacity of the appliance, and water at a temperature lower than that requested on the remote control is output. In this case, manually reducing the water flow at the tap will increase the temperature.

In the case of the 2007, there is no direct connection between the mechanical water flow control device with water flow sensor and the PCB, therefore, there could be occasions when the input required to heat the water exceeds the capacity of the appliance, and water at a temperature lower than that requested on the remote control is produced. In this case, annually reducing the water flow at top will increase the temperature.

Once hot water is flowing the water temperature thermistor senses the outgoing water temperature.

The PCB continually makes adjustments in order to maintain a constant temperature; [adjusting both the gas input and water flow in the case of the 2008 and 2408, where necessary.] It also continually monitors the combustion fan rpm adjusting the gas rate to match.

When the hot water tap is turned off, the water flow sensor stops revolving, and the magnetic pulse ceases, indicating to the PCB that there is no water flowing, in turn the PCB closes the gas valves. The combustion fan continues to operate for 65 seconds. This is to provide quicker ignition when the tap is turned on and off in rapid succession, as it removes the need for a pre-purge cycle, and allows the burner to re-light immediately when a hot water tap is opened again.

The PCB stores data on the calculated incoming water temperature, ready for when the hot water is turned on again. The data is used to calculate the initial gas flow.

18. Error Messages

Error messages are displayed as numbers flashing on the remote controls.

X = Does not operate

Error Code	Problem	Symptom	Main SV	Sld V	Changeover SV	Combustion Fan	Sparker
-	Water flow sensor faulty	Does not operate	X	X	X	X	X
71	Solenoid valve driving circuit faulty	Does not operate	X	X	X	X	X
72	Flame sensing device faulty	Does not operate	X	X	X	X	X
32	Short or faulty wiring in water temperature thermistor	Does not operate	X	X	X	X	X
-	Water flow control device faulty	Water flow is not controlled, water temperature incorrect	-	-	-	-	-
61	Combustion fan faulty	After 12.5 seconds operation	X	X	X	X	X
11	Sparker faulty	Stops without flame igniting	-	-	-	-	X
11	Main solenoid valve faulty	Stops without flame igniting	X	-	-	-	-
11	Solenoid valve faulty	Stops without flame igniting	-	X	-	-	-
-	Changeover solenoid valve faulty	Incorrect water temperature	-	-	X	-	-
12	Flame sensing device faulty	Stops second time burner has been extinguished	X	X	X	X	X
16	Outgoing water temperature abnormal	Operates, then stops	X	X	X	X	X
14	Remaining flame safety device operating	Operates, then stops	X	X	X	X	X
14	Thermal fuse faulty/blown	Operates, then stops	X	X	X	X	X
12	Earthing faulty	Does not operate	X	X	X	X	X
90	Fan (air) failure	Does not operate	X	X	X	X	X
10	Fan current abnormal	Operates, then stops	X	X	X	X	X
52	Mod. Sld valve answer abnormal	Operates, then stops	X	X	X	X	X

Notes

- Digital monitor does not illuminate when system is switched ON, or display drops out while appliance is operating.
 - Check power supply to the appliance.
 - Switch system OFF, the switch ON again, and re-attempt ignition.
- Appliance operates however symptoms remain, with digital display dropping out and error coded message flashing\
 - Isolate potentially faulty component using the component analysis table on page 45.

19. Diagnostic Points

Flow chart is on page 29.

Wiring diagram is on page 35.

Flow Chart No.	Measurement Point		Normal Value	Component
	CN	Wire Colour		
1	J ₄	brown-blue	AC 207~ 264 V	Surge Protector
2	H ₁	black - white	DC 10~ 13 V	Remote Controls
3	C ₂	red - black	DC 11~ 13 V	Water Flow Sensor
		yellow - black	DC 2~ 10 V	
4	D	white - black	DC 2~9 V	Combustion Fan Motor
	G	red - yellow	60~ 350 Hz	
5	A ₂	yellow - body earth	AC 100 ~ 160 V (over DC μ 1A	Flame rod
6	C ₁	white - white	Thermistor resistance value Temp resistance 15° C 11.4~ 14 k Ω 30° C 6.4~ 7.8 k Ω	Thermistor
7	B ₂	red - red	Below 1 Ω	Thermal Fuse
8	B ₃	red - red	Below 1 Ω	Over Heat Switch
9	I ₁	grey - grey	AC 90~ 110 V	Sparker
10	I ₁	pink - black	DC 80~ 100 V 0.9~ 1.3 k Ω	Solenoid Valve (SV ₂)
11	I ₂	yellow - black	DC 80~ 100 V 1.3~ 1.9 k Ω	Solenoid Valve (SV ₂)
12	B ₁	pink - pink	DC 0.5~ 25 V 60~ 100 Ω	Modulating Valve
13	I	blue - black	DC 80~ 100 V 1.3~ 1.9 k Ω	Solenoid Valve (SV ₃)
14	E ₁	red - blue	DC 11~ 13 V	Stepping motor
		orange - grey		

Transformer Voltages and Resistances

CN	Wire Colour	Normal Value
A	red - red	AC 90~ 110 V
F	green - green	AC 16~ 20 V
A	orange - orange	AC 13~ 30 V
A	brown - grey	AC 30~ 50 V
A	yellow - grey	AC 180~ 220 V

20. Wiring Diagram

- COLOUR CODING**
- W: White
 - Bk: Black
 - Br: Brown
 - R: Red
 - B: Blue
 - Y: Yellow
 - P: Pink
 - Or: Orange
 - Gr: Green
 - Gy: Grey

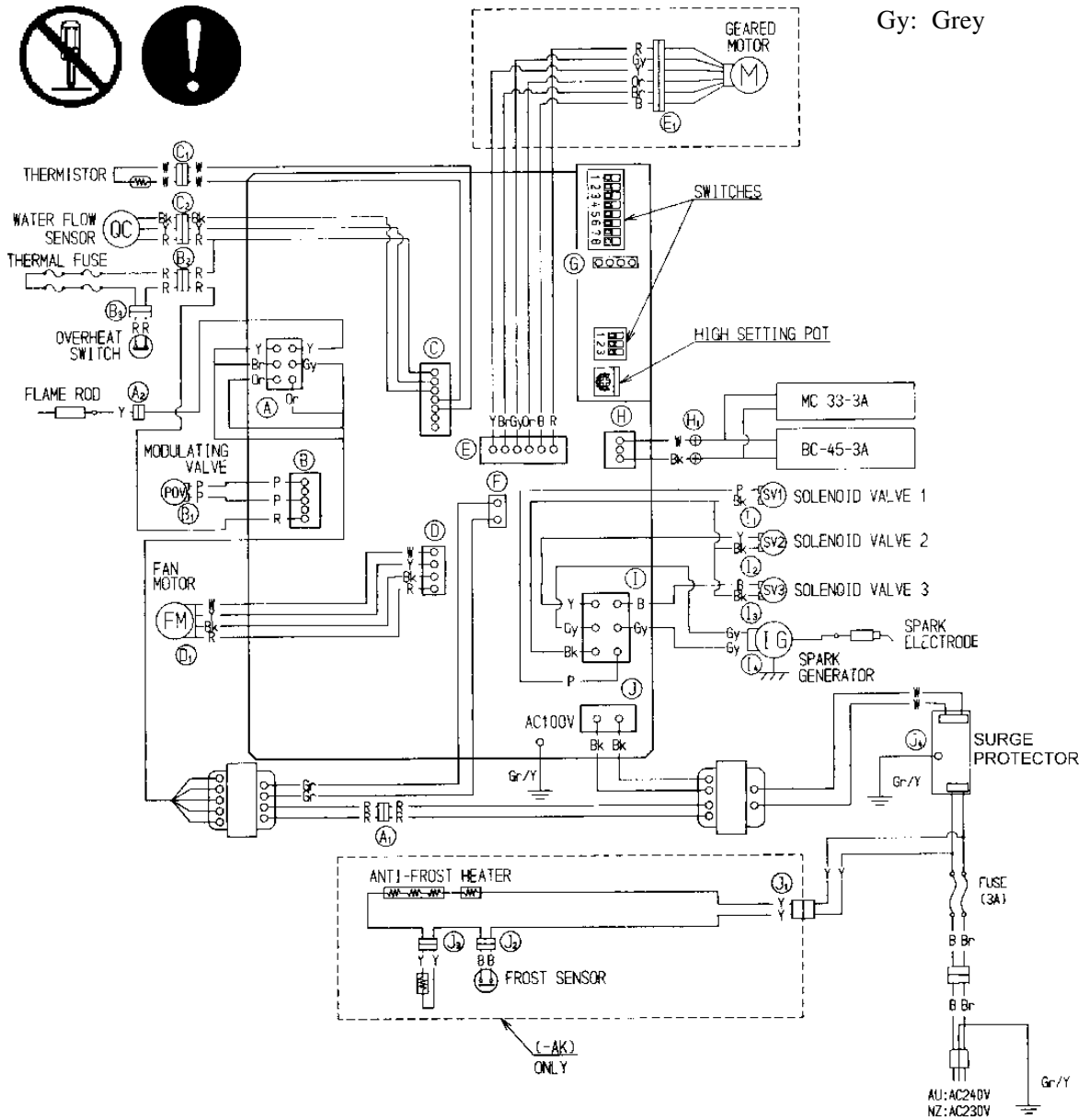

21. Fault Diagnosis



Before carrying out checks marked #, remove power cord from wall plug.
Wiring diagram is on page 35.

Appliance will to operate (even remote control fails to operate)	
1) Is the fuse blown?	
<p>Fuses are located in plastic holders in the main harness, on the lower right hand side of the appliance</p>	<p>Check fuse</p> <ol style="list-style-type: none"> a. Remove 240V plug from socket. b. # Measure resistance to check the electric fuse (3A). <p><i>Normal:</i> less than 1 Ω If normal, proceed to check item 2) below. <i>Faulty:</i> Replace fuse (5A) If it blows again, investigate cause of short circuit.</p>
2) Is the main transformer normal?	
	<p>Check the transformer.</p> <ol style="list-style-type: none"> a. Measure the voltage in between the red wires of the relay connector (A_1). <i>Normal:</i> AC90 ~ 110 V / 15 ~ 21 Ω If normal, check 2 below. <i>Faulty:</i> Check for AC 90 ~ 110 V on the PCB terminal J black ~ black b. Check voltages below at upper PCB connector A. <i>Normal:</i> orange -orange AC 13 ~ 30V / 1.4 ~ 1.8 Ω brown - grey AC 30 ~ 50V / 6 ~ 10 Ω yellow - grey AC 180 ~ 220V / 0.4 ~ 0.6 Ω If normal, check 3 at top of next page. <i>Faulty:</i> Replace the transformer.

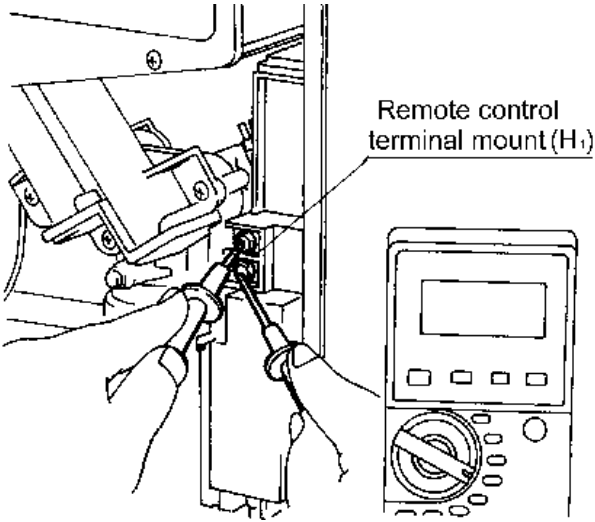
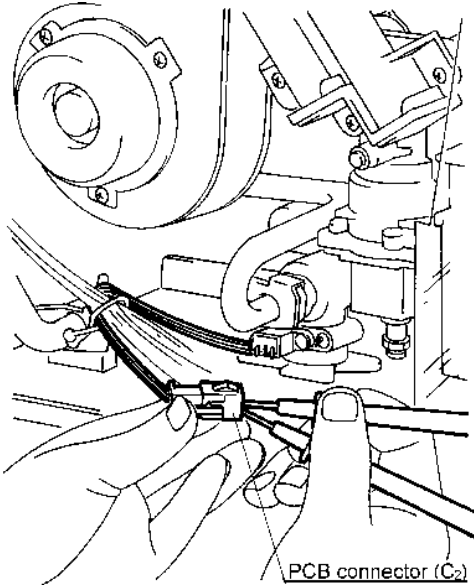
<p style="text-align: center;">Refer to diagram on bottom of previous page.</p>	<p>c. Check the voltage at centre PCB connector F, green~ green.</p> <p><i>Normal:</i> AC 16 ~ 20V If normal, check item 3) below.</p> <p><i>Faulty:</i> Replace the transformer.</p> <p>Note: Transformer voltage above applies to the appliance in a standby, non-functioning state.</p>
<p>3) Is the remote control normal?</p>	
 <p style="text-align: center;">Remote control terminal mount (H₁)</p>	<p>Check voltage between the two remote control cable conductors.</p> <p>a. Check the voltage between terminals on the remote control terminal mount (H₁).</p> <p><i>Normal:</i> DC 10 ~ 13V If normal, check for open circuit or shorts before replacing the remote control.</p> <p><i>Faulty:</i> Replace PCB.</p>
<p>No combustion (despite remote control indication)</p>	
<p>1) Is the water flow sensor normal?</p>	
 <p style="text-align: center;">PCB connector (C₂)</p>	<p>a. Measure the voltage between red and black of the relay connector (a₂).</p> <p><i>Normal:</i> DC 11 ~ 13V If normal, go to (b).</p> <p><i>Faulty:</i> Replace water flow control.</p> <p>b. Measure the voltage between yellow and black of the relay connector (a₂)</p> <p><i>Normal:</i> DC 2 ~ 10V If normal, go to 2).</p> <p><i>Faulty:</i> Replace the water flow sensor.</p>

2) Is the flame rod normal? Error “72” is displayed

Checking the flame rod.

- a. # Detach the flame rod terminal A₂, and re-attempt operation.

(“72” is displayed)

Proceed to check item 3) below.

(“72” is not displayed)

Inspect for electrical current leak from the flame rod.

Measure resistance between flame rod terminal A₂ and the appliance earth.

Normal: 1 M

4) Is the combustion fan normal?

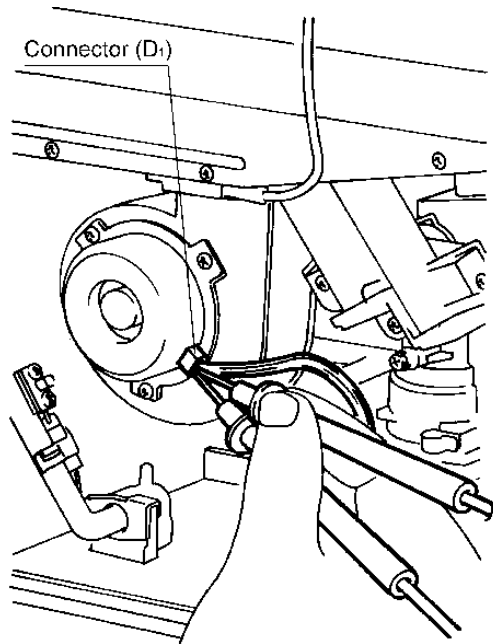

Motor check

If error “61” is displayed, check combustion fan.

- a. Measure the voltage at the connector (D₁)
black ~ red

Normal: DC 6~40V (fan on)

DC 0V (fan off)

If normal, go (b)

Faulty: Replace the PCB unit

Fan Revolution Sensor Check

- b. Measure the voltage at connector D₁,
black ~ yellow

Normal: DC 11~13V

If normal, go (b) below

Faulty: Replace the PCB unit

- c. Measure the voltage at connector D₁,
black ~ white

Normal: DC 2~9V

If normal, proceed to check item 5) below

Faulty: Replace the combustion fan.

5) Is the sparker operating normally?

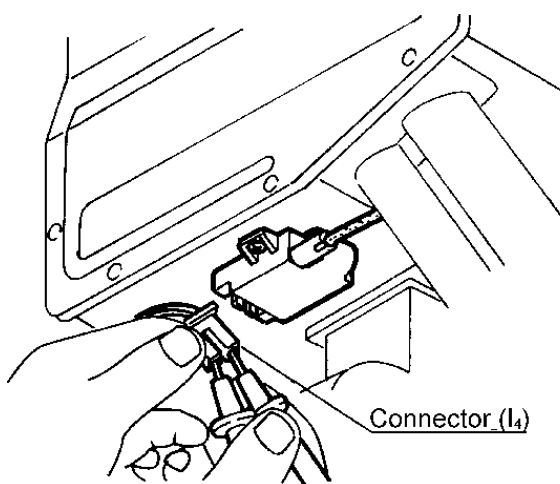

Checking the motor

- a. Measure the voltage at connector I₄.
grey ~ grey

Normal: DC 90 ~ 110 V

DC 0 V (when fan is OFF)

If normal, check (b) below.

Faulty: Replace the PCB unit

- b. # Disconnect I₄, and measure the
resistance between sparker terminals

Normal: > 1MΩ

If there is no spark, adjust or replace the electrode.

Faulty: Replace the sparker.

6) Is main gas solenoid valve (SV₁) normal?

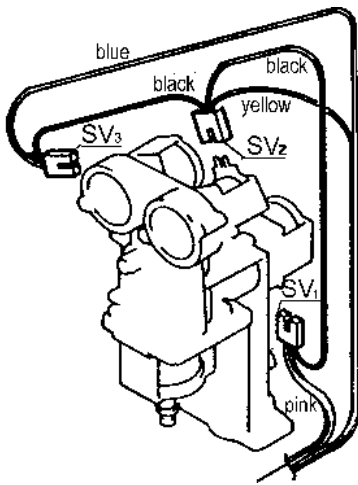

If error “11” is displayed, check the main gas solenoid valve.

- a. # Disconnect the main gas solenoid valve (SV₁), connector and measure the resistance at the solenoid terminals.
Normal: 0.9 ~ 1.3 k Ω
If normal, check (b) below.
Faulty: Replace the main gas solenoid valve.
- b. Measure voltage main gas solenoid valve (SV₂) pink ~ black connector.
Normal: DC80~ 100V
If normal, proceed to check item 7) below.
Faulty: Replace the PCB unit.

7) Is the change over solenoid (SV₂) operating normally?

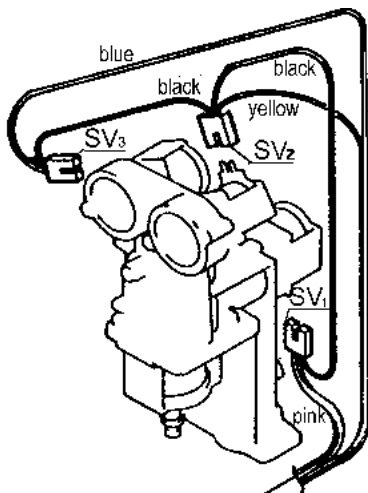

If error “11” is displayed, check the change over solenoid valve (SV₂).

- a. # Disconnect the main gas solenoid valve (SV₂) connector, and measure the resistance at the solenoid terminals.
Normal: 1.3 ~ 1.9 k Ω .
If normal, check (b) below.
Faulty: Replace the change over solenoid valve (SV₂).
- b. Measure voltage at change over solenoid valve (SV₃) blue ~ black connector.
Normal: DC 80 ~ 100V
If normal, check item 9) below.
Faulty: Replace the PCB unit

8) Is the change over solenoid valve (SV₃) normal?

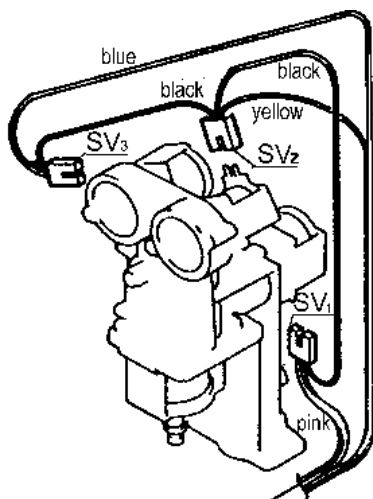

- a. # Disconnect the change over solenoid valve (SV₃) connector, and measure the resistance at the solenoid terminals.
Normal: 1.3 ~ 1.9 k Ω
If normal, check (b) below.
Faulty: Replace the change over solenoid valve (SV₃).
- b. Measure the voltage at changeover solenoid valve (SV₃) blue ~ black connector.
Normal: DC 80 ~ 100V
If normal, check item 9).
Faulty: Replace the PCB unit.

9) Are the safety devices operating normally?

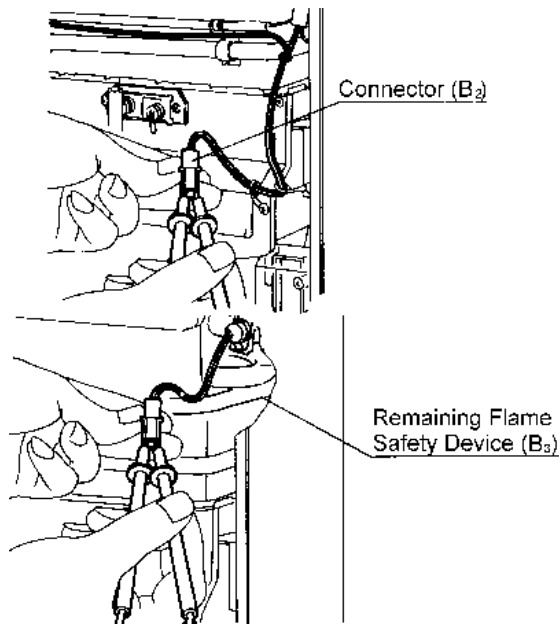

Check the thermal fuse.

- a. # Disconnect connector B₂ and measure the resistance between red ~ red.

Normal: less than 1 Ω.

If normal, replace the PCB unit.

Faulty: Check the appliance for damage. If there is nothing abnormal, replace the thermal fuse.

Check the remaining flame safety device.

- b. Measure resistance between the two terminals B₃.

Normal: less than 1 Ω

If normal, replace the PCB unit.

Faulty: Replace the remaining flame safety device.

Combustion stops due to flame failure

1) Is the flame rod functioning normally?

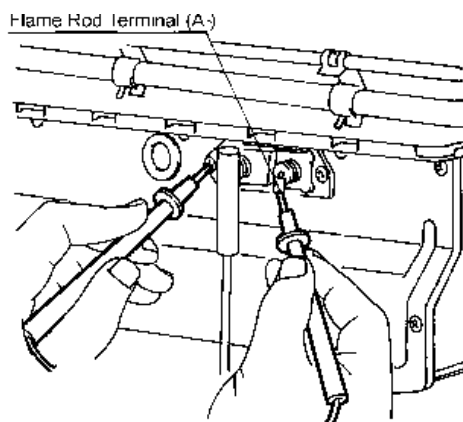

- a. Measure the voltage between the flame rod terminal (A₂) and the appliance earth.

Normal: AC 100 ~ 160V

If normal, check (b) below.

Faulty: Replace the PCB unit.

- b. Check that the flame rod attachment is not loose.

Normal: Replace the PCB unit

Faulty: Secure the flame rod brackets.

2) Is the earth lead wire normal?

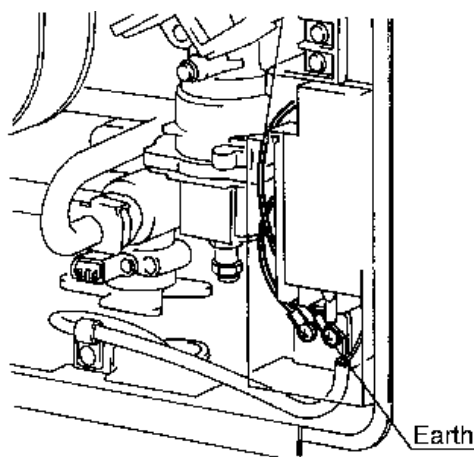

- a. Check whether the earth lead wire has come loose (disconnection from round terminal) or if any shorts have occurred. If normal, check for any other causes for flame failure (eg. gas valve is open, blocked filter, etc)

Faulty: Secure the earth.

Unable to adjust hot water temperature

1) Is the water temperature thermistor normal?

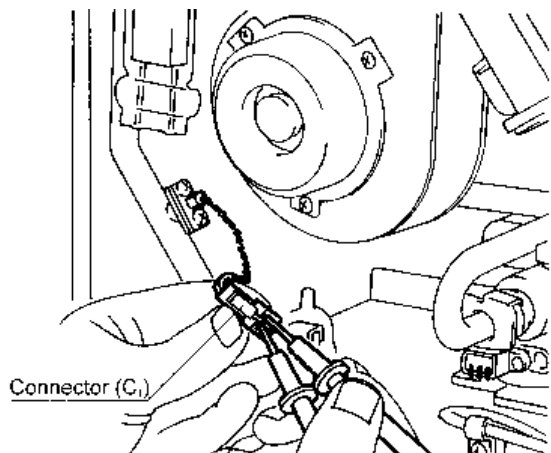

- a. Disconnect the connector (C_1) and measure the resistance between white wires.

See diagnostic points, for temperature at various resistance.

Normal: Proceed to check item 2) below
Faulty: Replace water temperature thermistor.

2) Is the changeover solenoid valve (SV_3) normal?

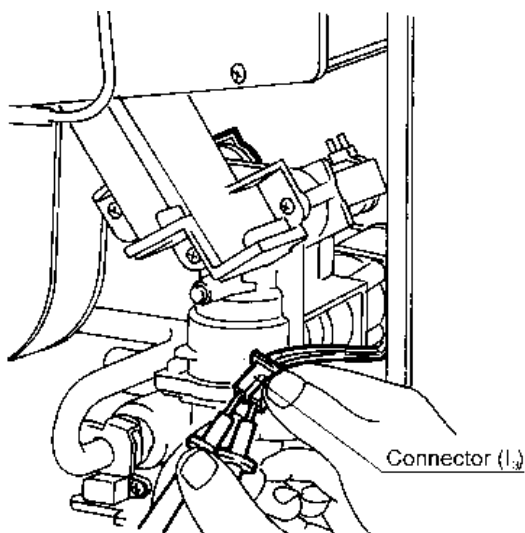

- a. # Disconnect the changeover solenoid valve (SV_3) connector, and measure the resistance between the solenoid terminals.

Normal: 1.3 ~ 1.9 k Ω .

If normal, go to (b).

Faulty: Replace the changeover solenoid valve (SV_3).

- b. Measure the voltage at the changeover solenoid (SV_3) blue ~ black connector.

Normal: DC 80 ~ 100V

If normal, go to item 3) on the next page.

Faulty: Replace the PCB unit.

3) Is the modulating valve operating normal?

- a. # Disconnect the modulating valve festoon terminals and measure the resistance at the terminals.

Normal: 60 ~ 100

If normal, go to (b).

Faulty: Replace the modulating valve.

- b. Re-connect terminal and measure the pink ~ pink voltage at the modulating valve festoon terminal.

Normal: DC 0.5 ~ 25 V

If normal, go to (c) below.

Faulty: Replace PCB unit.

- c. Investigate the change in gas secondary pressure when the remote control preset temperature is altered from 37 to 75 C.

Normal: If the secondary pressure changes, proceed to check item 4) below.

Faulty: Replace the modulating valve.

4) Is the water flow servo normal? (2008/2408)

- a. # Disconnect connector and measure the red ~ blue resistance on the water flow servo side.

Normal: 10 ~ 30

Anti frost heater does not operate

1) Are the ceramic anti-frost heaters OK?

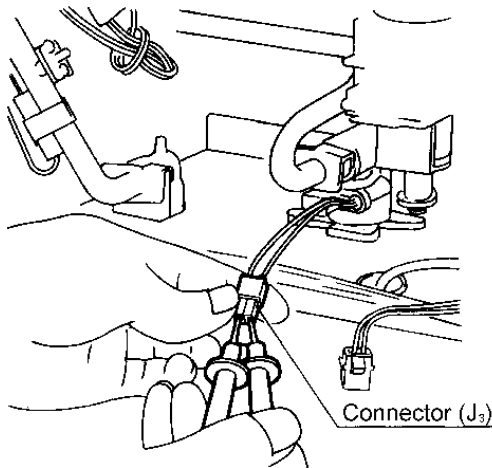

- a. # Disconnect connector (J₃) and measure the blue and blue resistance on the water control heater side.

Normal: 950~ 1050Ω (2424, 2408, 2008)
590 ~ 660Ω (2007)

If normal, go to (b).

Faulty: Replace the water control heater (2424, 2408, 2008).

Replace the anti-frost heater D assy (2007).

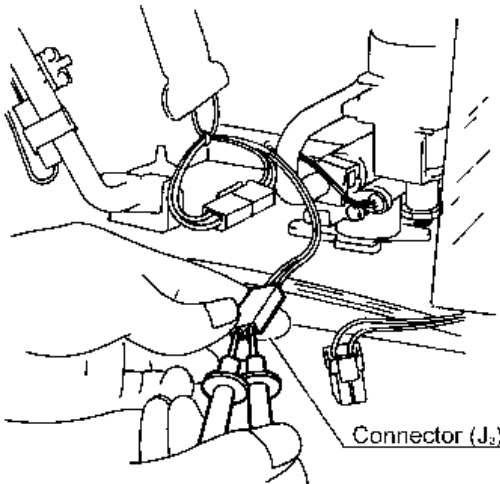

- b. # Disconnect connector (J₃) and measure the resistance between blue and blue on the heater exchanger's heater side.

Normal: 135 ~ 175Ω

If normal, go to item 2) below.

Faulty: Replace anti-frost heater (assy)

2) Is the frost sensing switch normal?

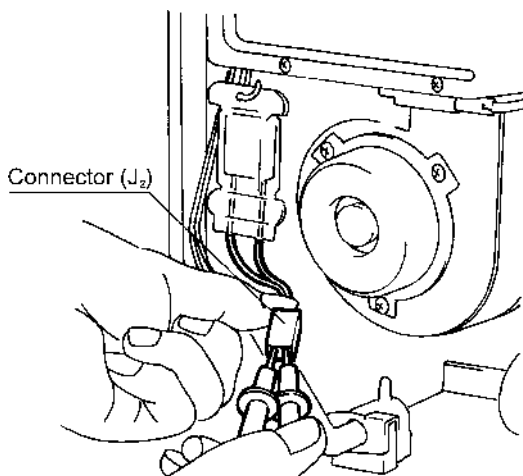

- a. # Detach connector (J₂) and measure the resistance between blue and blue.

*Measure at room temperature of 4± 3° C.**

Normal: Less than 1Ω

if normal, check the wiring (AC100V circuit)

Faulty: Replace the frost sensing switch.

* Where the low room temperature cannot be achieved, please cool with iced water or cold water below 4° C.

22. Electrical Component Analysis

Before starting inspection, re-check wiring harnesses and double check that all connections are tight.

Before carrying out checks marked with *, remove power cord from wall plug.

Nature of Fault	Examination Point	Diagnostic Point	Values	Y/N	Action	Repair N ^o
A. The ON indicator does not light up after switching the unit on.	1. Is the power cord plugged in?	Inspect visually	Is it plugged in?	Yes	Go to A-1.	
				No	Plug in cord	1
	2. Is supply voltage correct?	Measure voltage at power point.	AC 240 V (NZ 230 V)	Yes	Go to A - 3.	
				No	Check power supply circuit. Check fuses.	2
	3. Check 3 Amp electrical fuses.	*Inspect visually	Is the surge protector indicator lit up	Yes	Go to A-5	
				No	Go to A-6	
	4. Check 3 Amp electrical fuses.	* Disconnect and measure resistance to confirm if fuse is blown. Normal < 1 M Ω	Is fuse blown?	Yes	Go to A - 5 and replace fuse.	
				No	Go to A - 6.	
	5. Check for short circuits.	i) Measure the resistance of each solenoid valve. * Remove connector I from the PCB before measuring. Pink - Black 0.9 ~ 1.3 k Ω Yellow - Black 1.3 ~ 1.9 k Ω Blue - Black 1.5 ~ 1.9 k Ω	Are values within those specified at left? N.B. Measure after checking that there are no broken wires or shorts.	Yes	Go to A-6-2)	
				No	Replace faulty solenoid valves.	
				ii) Measure the sparker resistance. * Disconnect the sparker connector I ₄ and measure the resistance between both terminals.	Is resistance > 1M Ω	Yes
				No	Replace sparker	4
				iii) Check wiring	Are there any shorts?	Yes
				No	Replace PCB	6
				6. Check 240V-100V transformer.	i) Measure voltage between red-red A ₁ connector.	AC 90~ 110 V
		No	Replace PCB.			
	ii) Measure voltage at connectors A, F with appliance on "standby". A, Green-Green AC16 ~ 20 V F, Orange-Orange AC13 ~ 30 V F, Brown-Grey AC30 ~ 50 V F, Yellow (LH)-Grey AC180 ~ 220 V	Are values within those specified at left?	Yes	Go to A-7.		
			No	Replace 240V transformer.	8	
7. Check the remote control (where connected).	Measure voltage between the control terminals at H ₁ .	DC10 ~ 13 V.	Yes	Check cable for shorts/broken wires; replace remote control.	9	
			No	Replace PCB.	10	

Nature of Fault	Examination Point	Diagnostic Point	Values	Y/N	Action	Repair N ^o
B. Digital monitor lights up, but combustion does not commence. (When remotes are connected)	1. Check water flow sensor.	i) Measure voltage between red-black at connector C ₂	DC11 ~ 13 V.	Yes	Go to B-1-ii)	
				No	Replace PCB	11
		ii) Measure voltage between yellow-black at connector C ₂	DC2 ~ 10 V	Yes	Go to B-ii).	
				No	Replace water flow sensor.	12
Error code "72" displayed on digital monitor	2. Check flame rod.	* Measure resistance between flame rod terminal A ₂ and earth.	Resistance > 1M Ω	Yes	Replace PCB.	13
				No	Replace flame rod.	14
Error code "32" displayed	3. Check outgoing water temperature thermistor.	* Disconnect connector C ₁ and measure resistance of resistance Open circuit: > 1M Ω Short circuit: < 1 Ω	Are values as shown at left?	Yes	Replace water temp. thermistor.	15
				No	Go to B-4.	
Error code "61" displayed on digital monitor	4. Check combustion fan.	i) Check motor. Measure voltage between black-red at connector D ₁ .	DC6 ~ 40 V (Fan ON) DC 0 V (Fan OFF)	Yes	Go to B-5-ii).	
				No	Replace PCB.	16
		ii) Check rotation sensor. Measure voltage between black-yellow at connector D ₁ .	DC11 ~ 13V	Yes	Go to B-4-iv).	
				No	Replace combustion fan.	18
		iii) Measure voltage between black-white of connector D ₁ .	DC2 ~ 9V.	Yes	Go to B-v.	
				No	Replace PCB	19
Error code "11" displayed on digital monitor	5. Check sparker.	i) Measure voltage btwn grey-grey at connector I ₄ (sparker ON)	AC90~ 110 V.	Yes	Go to B-5-ii).	
				No	Replace PCB.	20
		ii) * Remove connector I ₄ ; measure resistance btwn sparker terminals.	Is resistance > 1M Ω	Yes	Go to B-5-iii).	
				No	Replace sparker.	21
		iii) Check if unit is sparking.	Is the sparker sparking?	Yes	Go to B-6.	
				No	Adjust/replace electrode.	22
	6. Check main gas solenoid valve (SV ₁).	i) * Disconnect main sld connector I from PCB. Measure resistance btwn pink-blk.	0.9 ~ 1.3k Ω	Yes	Go to B-6-ii).	
				No	Replace main solenoid (SV ₁).	23
		ii) Measure voltage between pink-black of SV ₁ connector.	DC80~ 100V	Yes	Go to B-7.	
				No	Replace PCB.	24
7. Check solenoid valve (SV ₂).	i) * Disconnect connector I from PCB; measure resistance between yellow-black.	1.3 ~ 1.9k Ω	Yes	Go to B-7-ii).		
			No	Replace (SV ₂).	25	
	ii) Measure voltage between yellow-black of SV ₂ connector.	DC80~ 100V	Yes	Go to B-8.		
			No	Replace PCB.	26	

Error code "11" displayed on digital monitor	8. Check changeover solenoid valve (SV ₃).	i) * Disconnect connector I from PCB; measure resistance between blue-black.	1.3~1.9k
--	---	--	----------

Nature of Fault	Examination Point	Diagnostic Point	Values	Y/N	Action	Repair N°
D. Can not adjust water temperature.	4. Check water flow servo.	i) Measure resistance between red-blue water flow servo connector I ₁ .	10 ~ 30 Ω	Yes	Go to D-4-ii).	
				No	Replace water flow servo with sensor.	42
		ii) Measure voltage between orange (+) - grey (-) water flow servo connector I ₁ .	DC11~ 13V	Yes	Go to -4-iii).	
				No	Replace PCB.	43
		iii) Measure voltage between brown-grey water flow servo connector I ₁ (don't turn water ON).	DC4 ~ 6V	Yes	Go to D-4-iv).	
				No	Replace water flow servo with sensor.	44
iv) Measure voltage between yellow-grey water flow servo connector I ₁ (don't turn water ON).	Is voltage < DC 0.5V	Yes	Normal			
		No	Replace water flow servo with sensor.	45		
E. Anti-frost heater does not work.	1. Check anti-frost heater.	i) * Disconnect connector J ₃ ; measure resistance between blue-blue (water valve)	950~ 1050Ω (2424,2408,2008) 590~ 600Ω (2007)	Yes	Go to E-1-ii).	
				No	Replace anti-frost heater (assy).	46
		ii) * Disconnect connectors J ₃ ; measure resistance between blue-blue. (heat exchanger).	135~ 170Ω	Yes	Go to E-2.	
				No	Replace anti-frost B (assy).	47
	2. Check frost sensing switch.	Disconnect connector f ₃ ; measure the resistance between blue-blue. Atmospheric temperature less than 4±3 °C.	Is resistance < 1Ω	Yes	Check wiring.	
				No	Replace frost sensing switch.	48

23. Gas Conversion



1. Remove outer cover, 4 screws.
2. Delete “gas type marking” from the combustion chamber cover and replace with “new gas type”.
(Use a black marking pen)
3. Delete gas type from small paper sticker on bottom edge of inner casing.
4. Replace small gas label on gas inlet.
5. Replace large gas label on top of appliance.
6. Place “new” very small gas label (indicating new gas type) over existing one on data plate.
7. Complete details on conversion sticker, place sticker on the inside front cover.
8. Remove PCB protective plastic cover.
9. Disconnect flame sensor and sparker lead.
10. Remove combustion chamber cover, 11 screws.
11. Remove manifold, 5 screws.
12. Fit or remove damper assembly (3 screws) depending on gas type. Note: Damper is only used on LPG models.
13. Fit new manifold, ensuring no wires are trapped. Check “O” rings are correctly positioned.
14. Refit combustion chamber cover. Attach flame sensor and sparker lead.
15. Connect appliance to gas, water, and electricity.
16. Follow gas pressure setting procedure, (see next page).
17. Check for gas escapes with soapy water.
18. Disconnect appliance from services (if in workshop).
19. Replace front cover, star washer must be on bottom right hand screw.

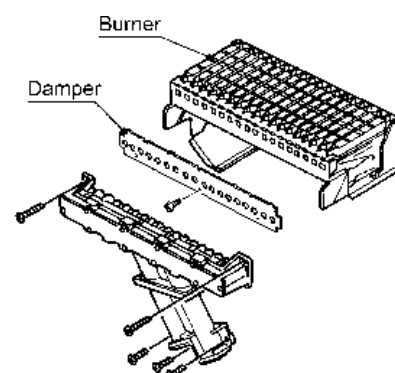
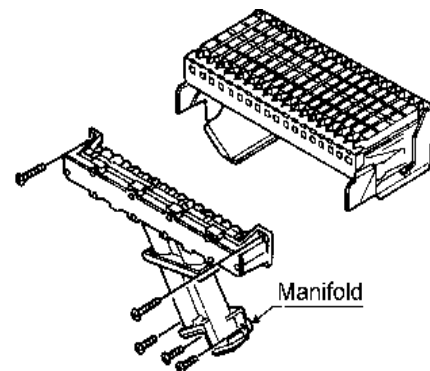
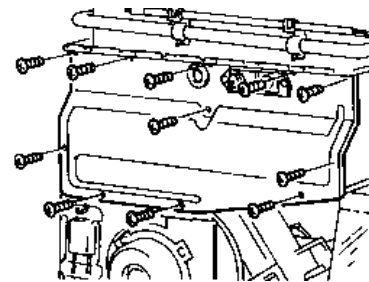
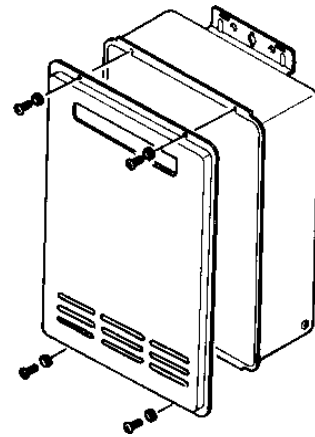

24. Gas Pressure Setting Procedure

Position gas selection switches to the correct position. (see diagram opposite).

Remove pressure point screw and attach pressure gauge.

Turn water ON.

Adjust pressure

1) Low

- a. Position No. 2 of the bottom set of dip switches to ON.
- b. Remove the plug in the base of the appliance for access to the regulator screw (modulating valve).
Unlock screw and adjust to:
Natural - 0.8 kPa
Propane - 0.17 kPa
LPG (NZ) - 0.15 kPa

c. Lock regulator screw (modulating valve).

2) High

- a. Position No. 3 of the bottom set of dip switches to the ON position (leaving No.2 ON).
- b. 2007/2008: using the HI potentiometer on the PCB, adjust the pressure to:
Natural - 0.65 kPa
Propane - 1.60 kPa
LPG (NZ) - 1.51 kPa

2424/2408: using the HI potentiometer on the PCB, adjust the pressure to:
Natural - 0.90 kPa
Propane - 2.26 kPa
LPG (NZ) 1.90 kPa

- c. Position switch No.2 and No.3 of the bottom set of dip switches to the "OFF" position.
- d. Turn water OFF. Replace plug in base.
- e. Replace protective plastic cover over PCB.

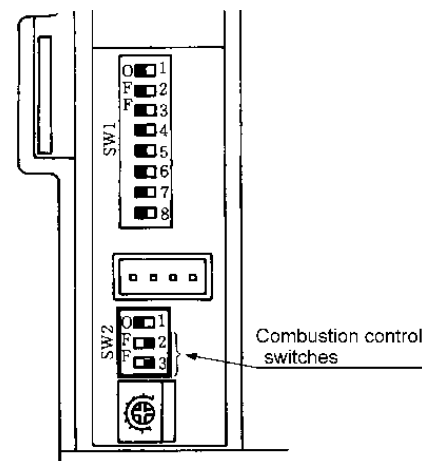
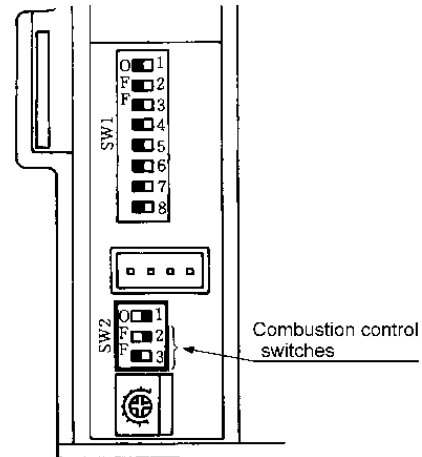
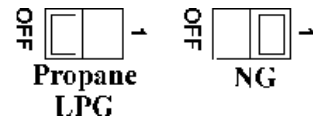

25. Dismantling for service



NOTE: Before proceeding with dismantling, be sure to follow the **CAUTION** instructions before each explanation.

e.g.- Isolate gas supply

- Disconnect electrical supply from wall socket.
- Isolate the water supply.
- Drain All water from the appliance

<i>Item</i>	<i>Page</i>
1. Removal of Front Panel	52
2. Removal of PCB.	52
3. Removal of Water Flow Sensor with Water Flow Servo	52
4. Removal of Sparker	53
5. Removal of Combustion Fan	53
6. Removal of Water Temperature Thermistor	53
7. Removal of Transformer	54
8. Removal of Manifold and Burner	54
9. Removal of Gas Control	55
10. Removal of Heat Exchanger	55
11. Removal of Thermal Fuse	56

Unless otherwise stated, reassemble is the reverse of dismantling

IMPORTANT

For some areas of dismantling you may need to isolate any or all of the following:

- * Isolate gas supply.
- * Disconnect electrical supply from wall socket.
- * Isolate water supply.
- * Drain **all** water from appliance.

The following diagram may be of assistance.

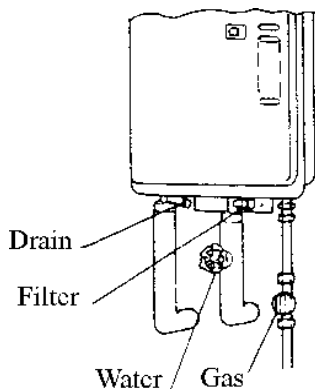

1) Removal of Front Panel

CAUTION

240 volt potential exposure. Isolate the appliance and reconfirm with a neon screwdriver or multimeter.

- a. Remove the four (4) screws holding the panel in place. (Phillips driver)

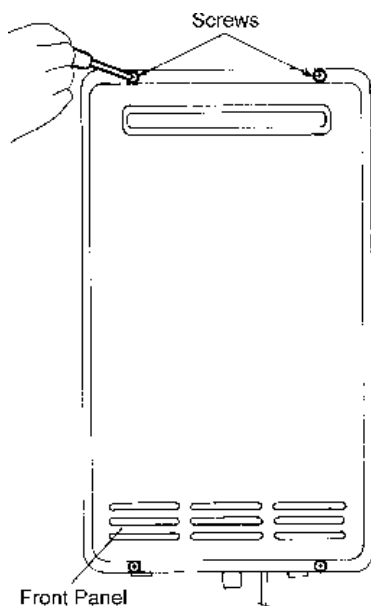

2) Removal of PCB

CAUTION

240 volt potential exposure. Isolate the appliance and reconfirm with a neon screwdriver or multimeter.

- a. Remove the 2 screws on the water flow control and pull out towards you. (Phillips driver)

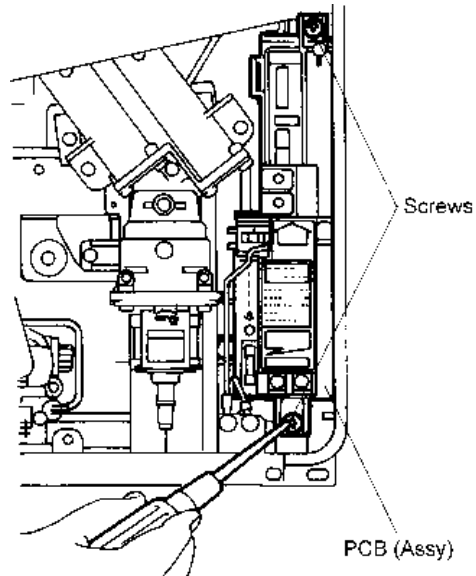

3) Removal of Water Flow Sensor with Water Flow Servo

CAUTION

240 volt potential exposure. Isolate the appliance and reconfirm with a neon screwdriver or multimeter.

- a. Remove one (1) screw from the heat exchanger water supply pipe to release the metal lock. Pull the pipe towards yourself to release. Handle O-ring carefully. (Phillips driver)

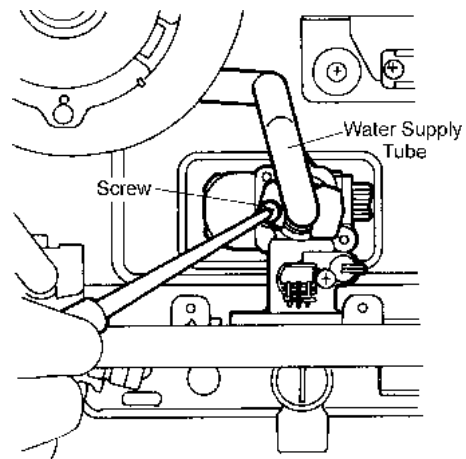

- b. Remove four (4) screws from the water supply connection and remove connection.
Handle O-ring carefully. (Phillips driver)

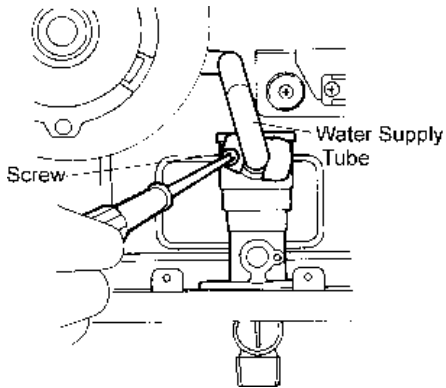

- c. Disconnect electrical connectors (2008,2408,2424 only) and remove water flow sensor from control assembly.

4) Removal of Sparker

CAUTION

240 volt potential exposure. Isolate the appliance and reconfirm with a neon screwdriver or multimeter.

- a. Remove one (1) screw that secures sparker to the attachment plate to remove sparker. (Phillips driver).
- b. Disconnect high tension lead connector.

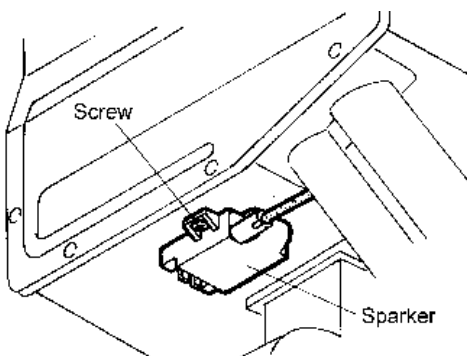

5) Removal of Combustion Fan

CAUTION

240 volt potential exposure. Isolate the appliance and reconfirm with a neon screwdriver or multimeter.

- a. Detach the sparker, refer to section 4.
- b. Remove the three (3) screws that secure the fan in place, disconnect connector and pull the fan towards yourself to remove it. (Phillips driver)

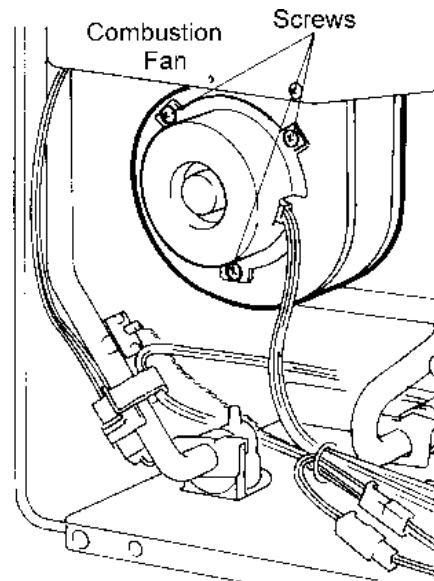

6) Removal of Water Temperature Thermistor

CAUTION

240 volt potential exposure. Isolate the appliance and reconfirm with a neon screwdriver or multimeter.

- a. Remove the two (2) screws that secure the thermistor in place to remove the water temperature thermistor. (Phillips driver)

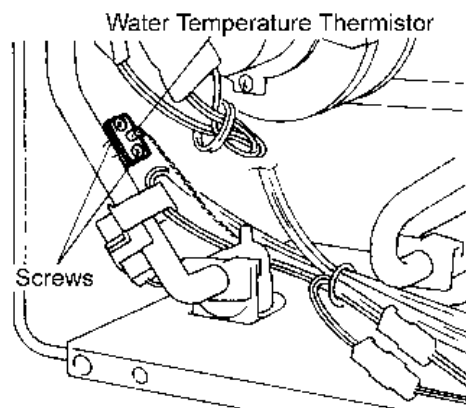

7) Removal of Transformer

CAUTION

240 volt potential exposure. Isolate the appliance and reconfirm with a neon screwdriver or multimeter.

- a. Remove the PCB unit; refer to section 2.
- b. Remove the sparker; refer to section 4.
- c. Remove one solenoid valve connector.
- d. Remove two (2) fixing screws to release the transformer (Phillips driver)
- e. Disconnect connectors.

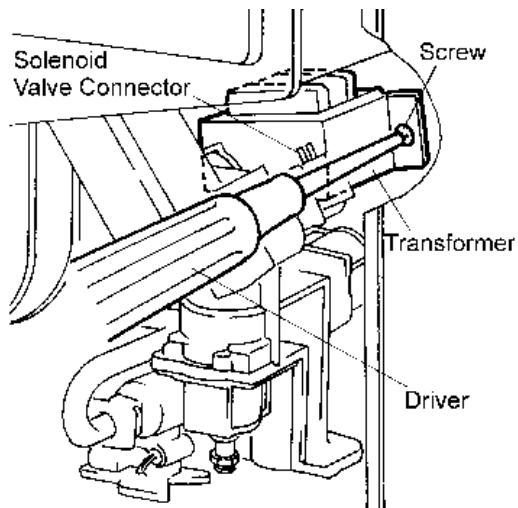

8) Removal of Manifold and Burner

CAUTION

240 volt potential exposure. Isolate the appliance and reconfirm with a neon screwdriver or multimeter.

- a. Remove the sparker, refer section 4. (1 screw)
- b. Remove eleven (11) screws that hold the combustion chamber front panel in place and remove the panel (Phillips driver)

Combustion Chamber Front Panel

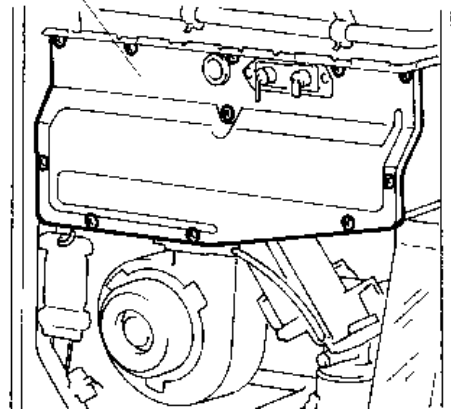

- c. Remove the five (5) screws that secure the manifold in place and pull out the manifold (Phillips driver).

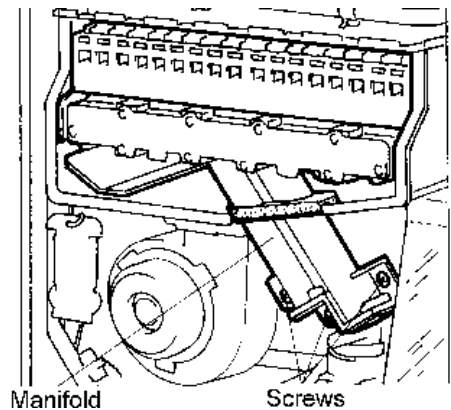

- d. Pull burner unit forward to remove (hand)

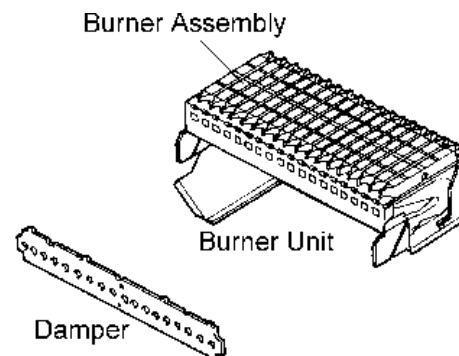

9) Removal of Gas Control

CAUTION

240 volt potential exposure. Isolate the appliance and reconfirm with a neon screwdriver or multimeter.

- Remove the manifold (5 screws), refer section 8a,b,c.
- Remove the four (4) screws that hold the gas connection and gas control in place. Remove the gas connection. Handle O-ring carefully. (Phillips driver)

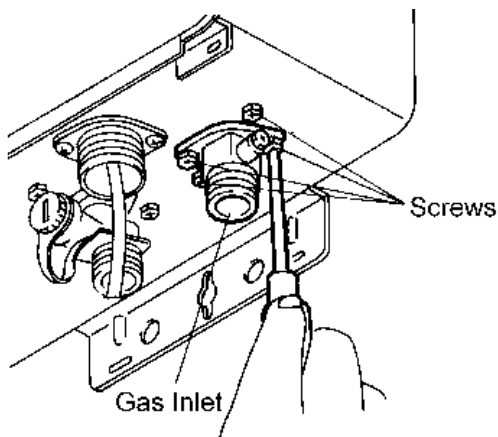

- Remove one (1) screw that holds the gas control in place, disconnect connectors, pull out the gas control.

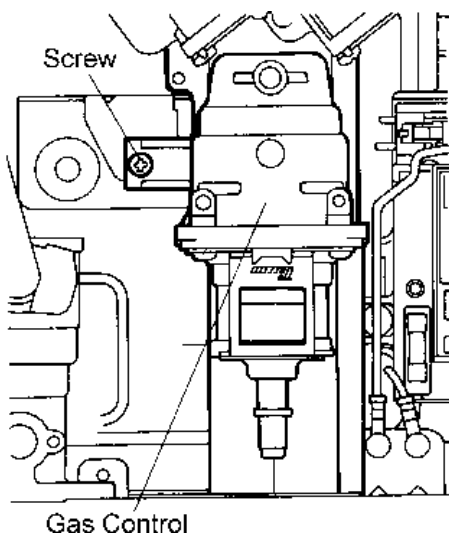

10) Removal of Heat Exchanger

CAUTION

240 volt potential exposure. Isolate the appliance and reconfirm with a neon screwdriver or multimeter.

- Remove PCB unit; refer to section 2-a.
- Remove the heat exchanger water connection pipe; refer to section 3-a.
- Remove one (1) screw from the outlet connection clip, to pull out the hot water supply connection pipe towards yourself. (Handle O-ring carefully)

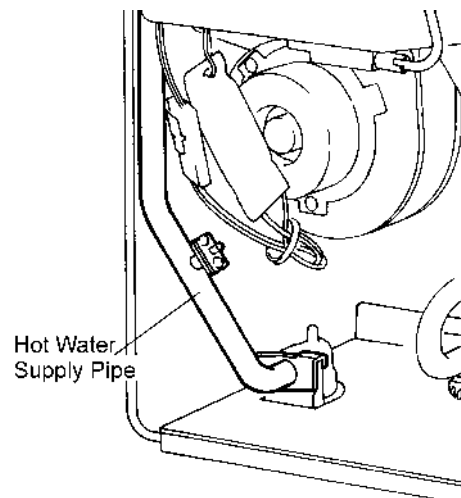

- Remove the three (3) screws securing the manifold to the gas control.
- Remove four (4) screws that secure the heat exchanger unit in place.

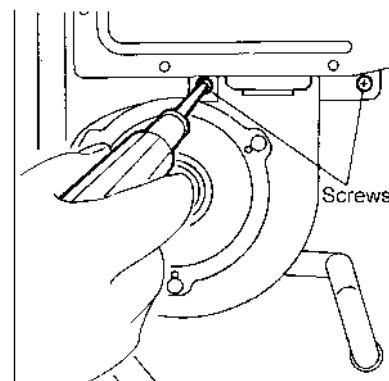
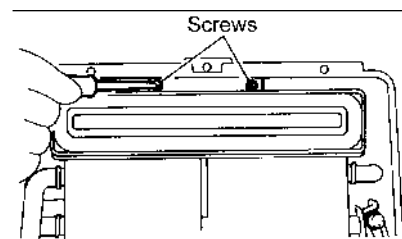

- f. Remove all electrical connectors, including the thermistor.
- g. Pull out the heat exchanger unit towards yourself.

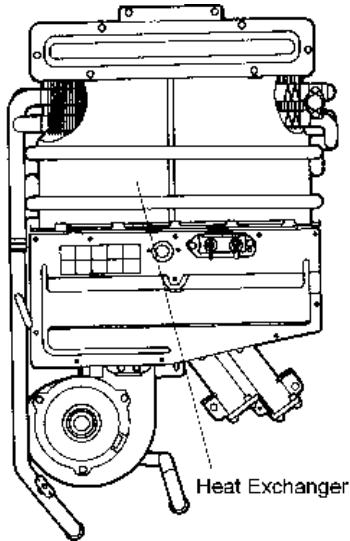

11) Removal of Thermal Fuse

CAUTION

240 volt potential exposure. Isolate the appliance and reconfirm with a neon screwdriver or multimeter.

- a. Remove the heat exchanger unit; refer to section 10.

- b. Disconnect and remove the thermal fuse (phillips head).

* Fit the fuse as shown below

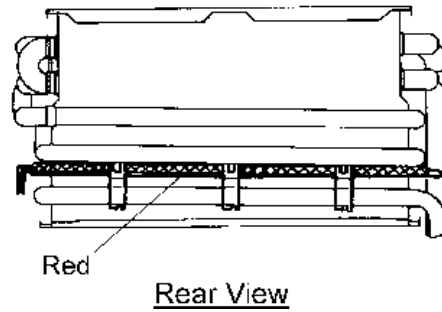
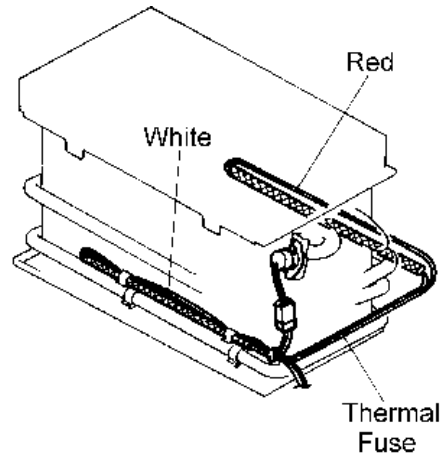

26. Exploded Diagram

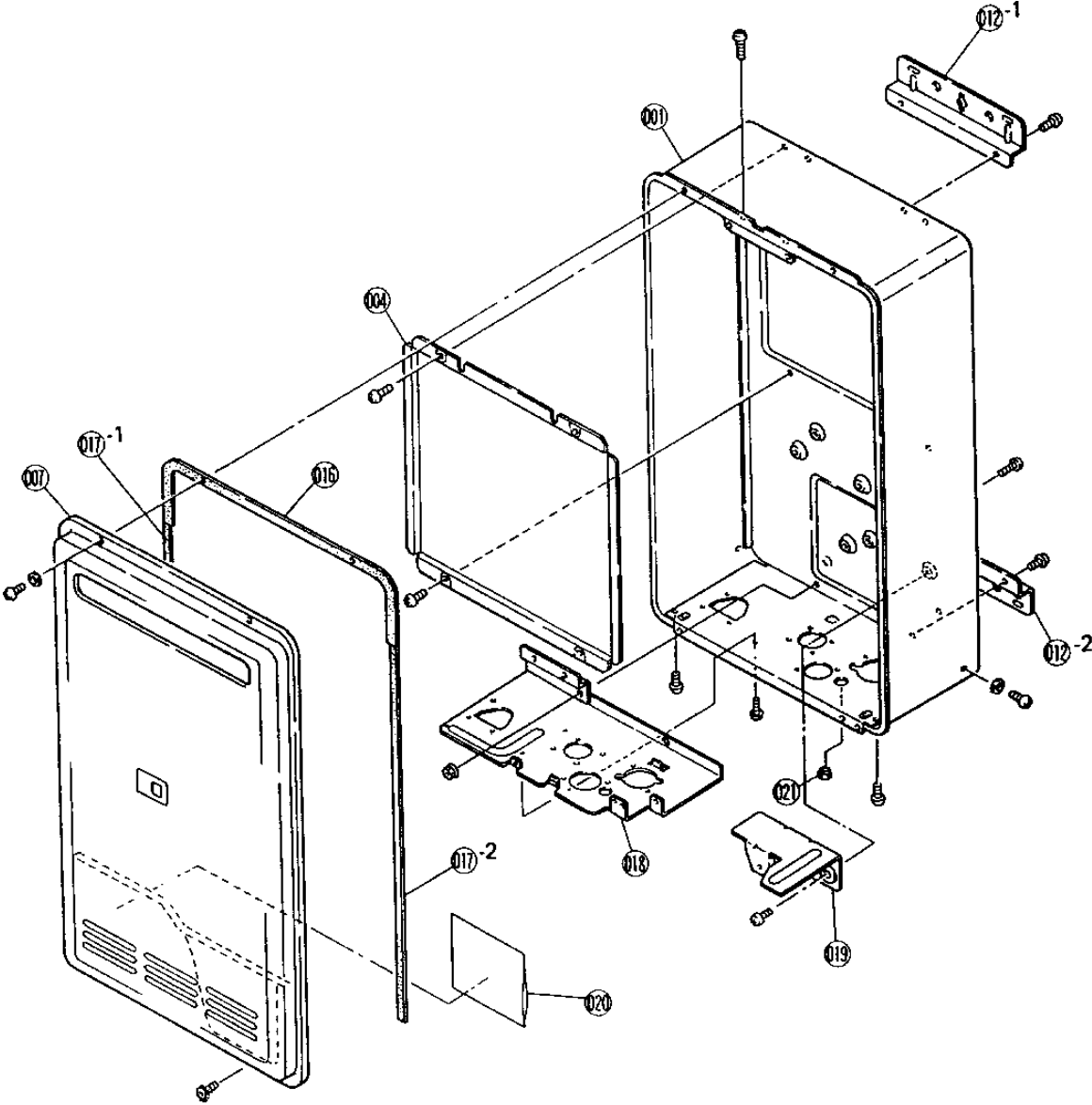

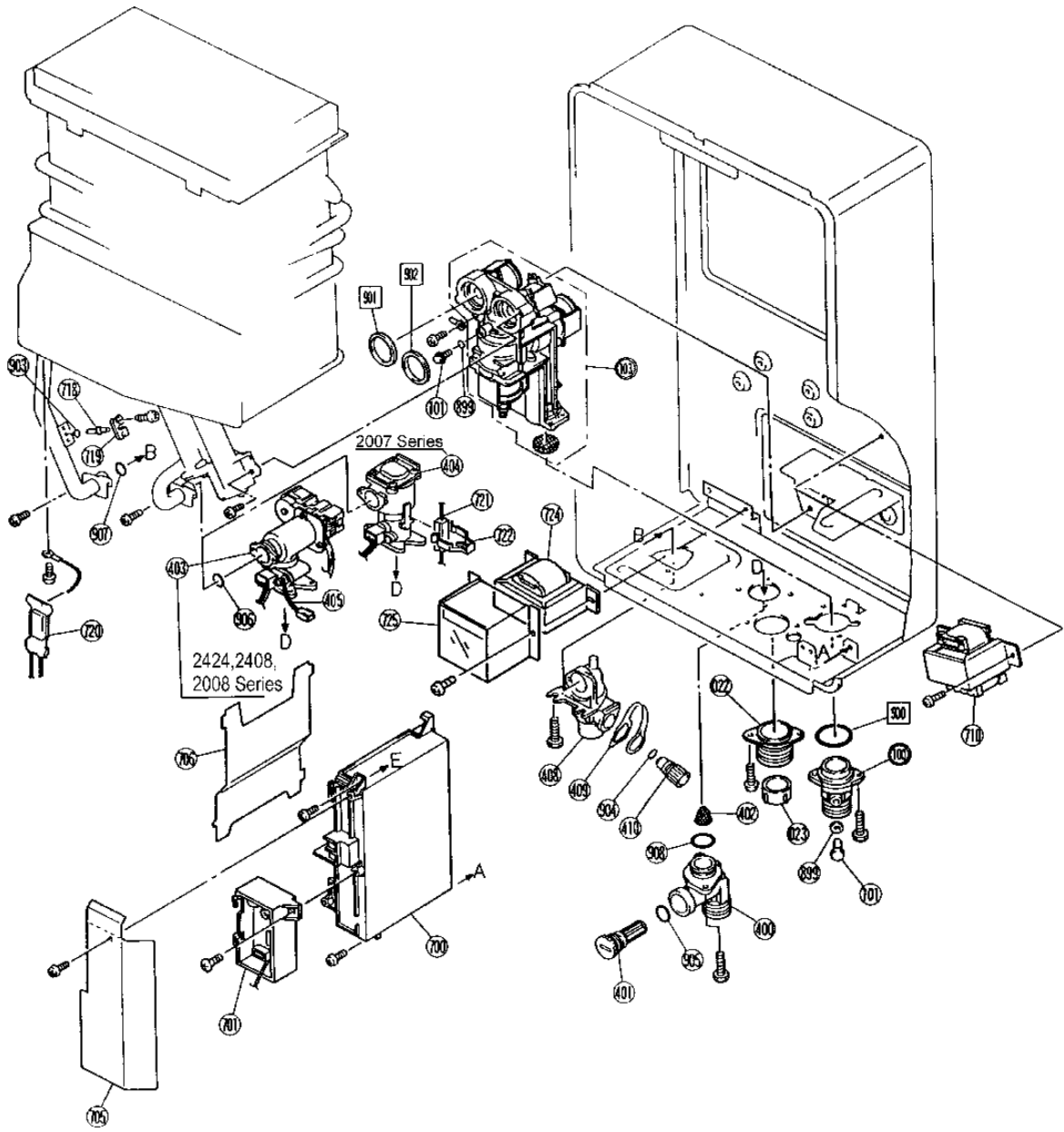

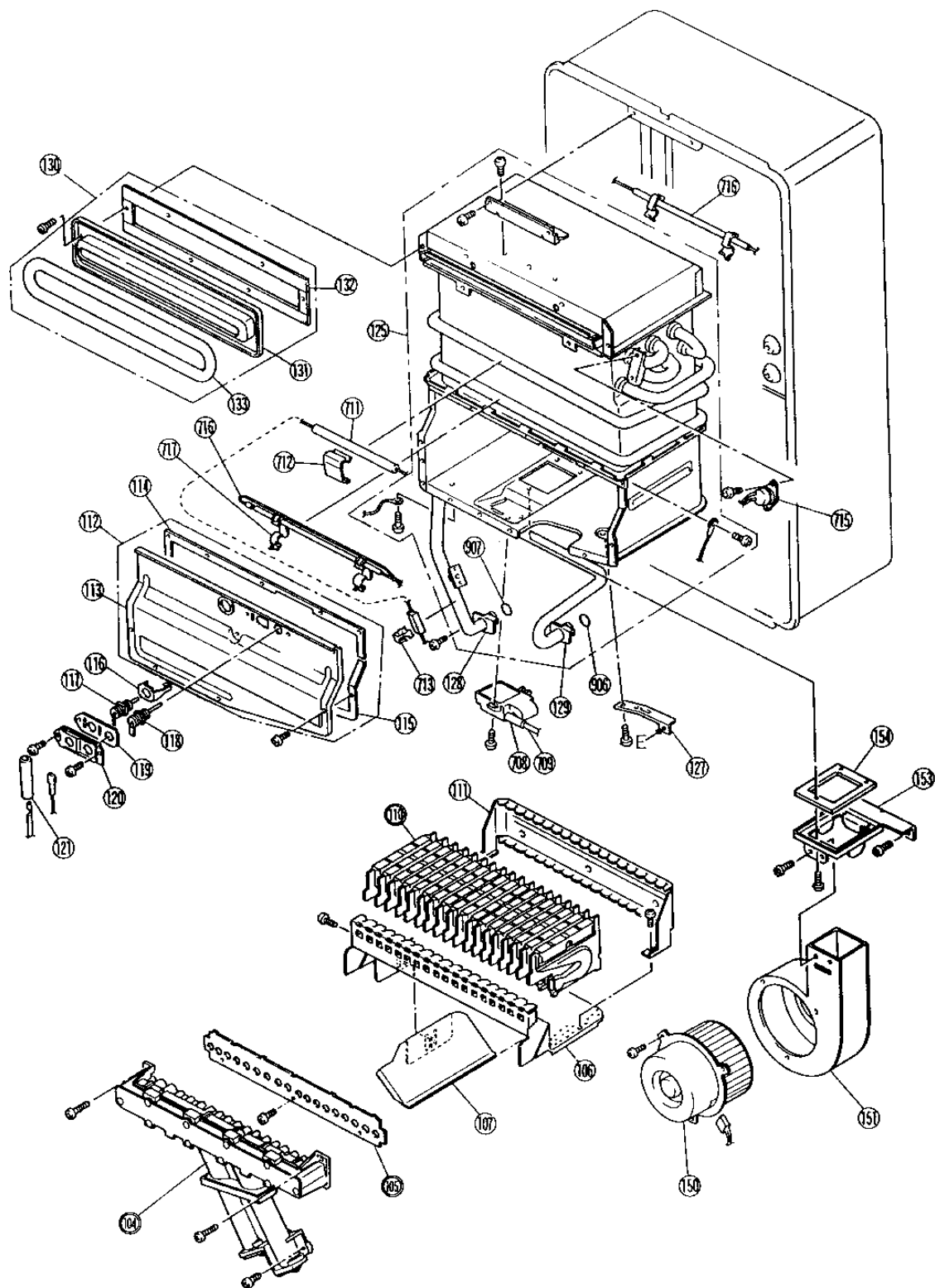

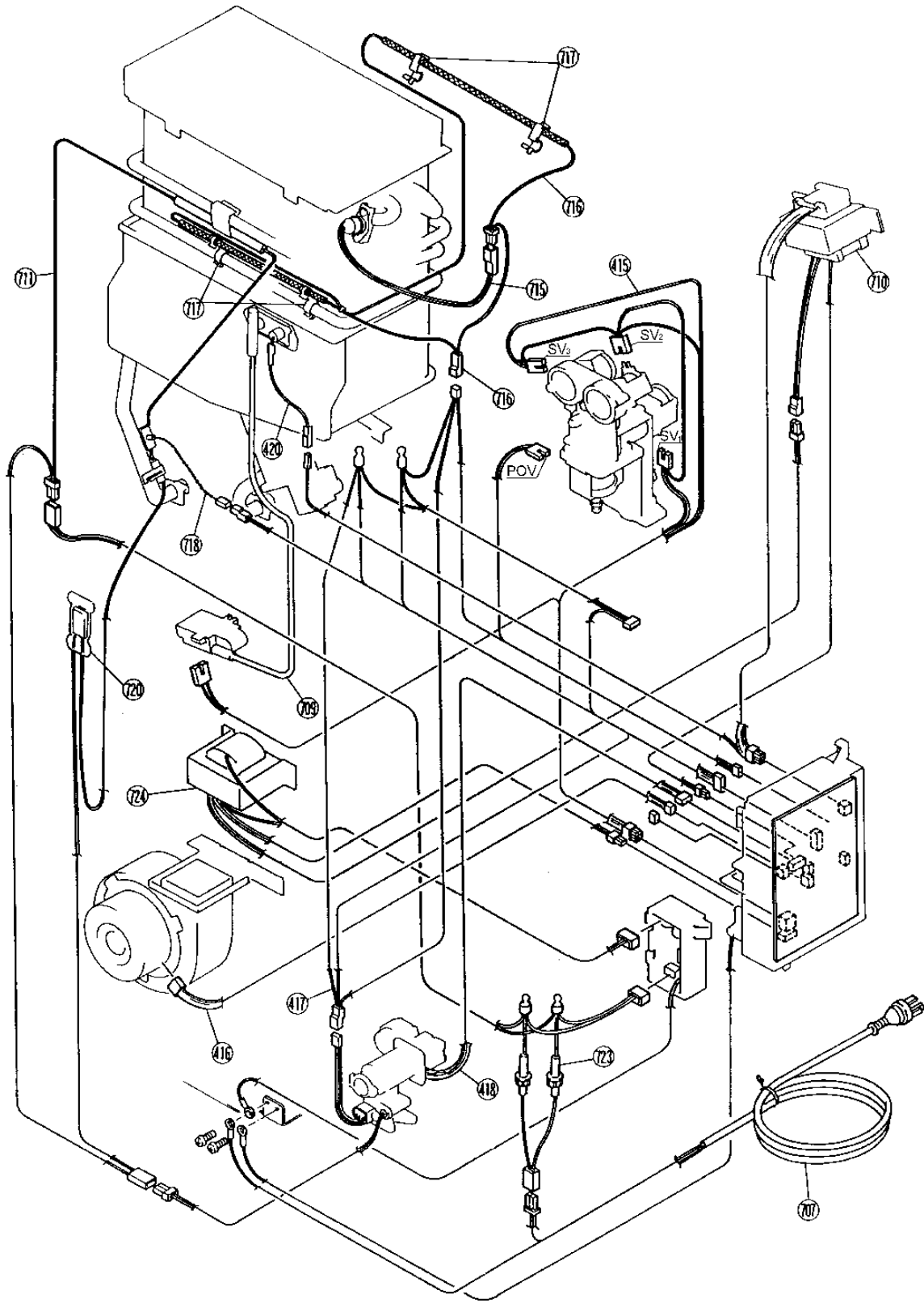

27. Parts List

No	Part Name	RA Part No	RNZ Part No	QTY
001	Main Body Assy - Standard			1
001	Main Body Assy - Salt Resistant		3044	1
004	Heat Shield			1
007	Front Panel Assy - Standard	92081561		1
007	Front Panel Assy - Salt Resistant		3047	1
012	Wall Bracket			2
016	Front Panel Packing			1
017	Main Body Packing - Side		3768	2
018	Connection Reinforcement Panel			1
019	Gas Control Bracket			1
020	Installation Sheet Storage Pouch			1
021	Rubber Plug			1
022	Cable Connection		3896	1
023	Cable Seal Packing			1
100	R3/4 / 20 Gas Connection	92081587	3074	1
101	Test Point Screw			2
103	Gas Control Assembly	92081595	3083	1
104	Manifold (Assembly) - NG		3125	1
104	Manifold (Assembly) - LPG	92081603	3089	1
105	Damper (LPG, Propane Gas)	92071364	3136	1
	Damper not required for Natural Gas			
106	Burner Case Front			1
107	Sound Proofing Panel			1
110	Burners (Front)		3393	18
111	Burner Case Back Panel			1
112	Comb. Chamber Front Panel (Compl. Assy)			1
113	Combustion Chamber Front Panel (Assy)			1
114	Combustion Chamber Packing - Top	92081629	3396	1
115	Combustion Chamber Packing - Bottom	92081637	3397	1
116	Ignition Target			1
117	Electrode	92072917	3208	1
118	Flame Rod Electrode	92072891	3218	1
119	Electrode Packing			1
120	Electrode Clip			1
121	Electrode Sleeve		3395	1
125	Heat Exchanger Complete Assy	92081660	3347	1

No	Part Name	RA Part No	RNZ Part No	QTY
127	PCB Bracket			1
128	Heat Exchanger Outlet O-ring			1
129	Heat Exchanger Inlet O-ring			1
130	Flue (Assy)	92081678		1
131	Flue Terminal			1
132	Flue Terminal Packing		3398	1
133	Front Panel / flue Sealing		3056	1
150	Fan Motor (Assy)	92081686	3348	1
151	Fan Casing			1
153	Fan Connection			1
154	Fan Connection Packing	92081694		1
400	R3/4 / 20 Water Inlet Connection B	92081702	3059	1
401	Inlet Filter (Assy)	92062280	3839	1
402	Water Flow Valve Filter		3048	1
403	Water Flow Servo & Sensor (Assy) (Anti-Frost) (2408,2008,24242)			1
403	Water Flow Servo (Assy) (2408,2008,2424)	92081728	3349	1
404	Auto. Water Flow Control & Sensor (2007)	92081736		1
405	Water Valve Heater	92082437		1
408	R3/4 / 20 Hot Water Outlet Connection	92081744	3373	1
409	Pressure Relief Valve Band			1
410	Pressure Relief Valve	92081751	3626	1
415	Modulating solenoid Valve Harness	92081769	3374	1
416	Fan Motor Harness		3375	1
417	Sensor Harness	92081777	3376	1
418	Water Flow Servo Harness	92081785	3380	1
420	Flame Rod Harness		3381	1
700	PCB (Assy)	92081793	3382	1
701	Surge Arrestor	92081801	3394	1
705	PCB Cover - Front		3383	1
706	PCB Cover- Side		3384	1
707	Electrical Cord		1893	1
708	Sparker	92081819	3385	1
709	High Tension Cord	92081827		1
710	PCB Transformer (Assy)	92081835	3386	1
711	240 V Anti-frost Heater B (Assy) [AK only]	92081843	2363	1
712	Heater Bracket [AK only]		2364	1

No	Part Name	RA Part No	RNZ Part No	QTY
713	Heater Bracket [AK only]		2032	1
715	Remaining Flame Safety Device	92081850	3387	1
716	Thermal Fuse	92081868	3388	1
717	Thermal Fuse Harness			5
718	Thermistor	92081876	3389	1
719	Thermistor Clip - Large		3882	1
720	Frost Sensing Switch	92081884	2362	1
721	240 V Anti-frost Heater A (Assy) [AK only]	92081892	3390	1
722	Heater Bracket [AK Only]			1
723	3 Amp Fuse Harness	92081900	3391	1
724	Transformer (Assy) (240 ~ 100 Volt)	92081918	3392	1
725	Transformer Cover			1
899	“O” Ring (S4)		2239	2
900	“O” Ring (P24)	92081926	3559	1
901	Packing		3619	1
902	Packing		3619	1
903	“O” Ring (P4)		3932	1
904	“O” Ring (P7)		3849	1
905	“O” Ring (P12)		1106	1
906	“O” Ring (P12.5)		3965	1
907	“O” Ring (P14)		3826	1
908	“O” Ring (P18)		3811	1

SERVICE CONTACT POINTS

Rinnai

AUSTRALIA PTY. LTD. ACN 005 138 769 ABN 74 005 138 769

Internet: <http://www.rinnai.com.au>

E-mail: enquiry@rinnai.com.au

Victoria :

Helpline:

Service

Spare Parts

Sales

Emergency Hot Water

Tel: 1300 366 388

Tel: (03) 9271 6699 Fax: (03) 9271 6688

Tel: (03) 9271 6600 Fax: (03) 9271 6688

Tel: (03) 9271 6666 Fax: (03) 9271 6611

Tel: (1800) 632 386

10-11 Walker Street, Braeside, VIC 3195

Tel: (03) 9271 6625 Fax: (03) 9271 6622

New South Wales:

Service

Sales

Emergency Hot Water

Tel: (02) 9609 2600 Fax: (02) 9729 0467

Tel: (02) 9609 2888 Fax: (02) 9609 5260

Tel: (02) 9729 0468

62 Elizabeth Street, Wetherill Park, NSW 2164

Tel: (02) 9609 2111 Fax: (02) 9609 5260

South Australia:

Service

Emergency Hot Water

Tel: (08) 8345 0292 Fax: (08) 8345 4760

Tel: (08) 8345 5185

140 Days Road, Ferryden Park, SA 5010

Western Australia:

Service

Emergency Hot Water

Tel: (08) 9478 3355 Fax: (08) 9277 2531

Tel: (08) 9324 4145

18 Belgravia Street, Belmont, WA 6104

Queensland:

Service

Emergency Hot Water

Tel: (07) 3209 4622 Fax: (07) 3209 4722

Tel: 0412 747 717.

1/6 Booran Drive, Logan Central, QLD 4114

Tasmania:

Service

Contact Rinnai Melbourne on:

Tel: (03) 9271 6699 Fax: (03) 9271 6688

Tel: (03) 9271 6625 Fax: (03) 9271 6622

Rinnai

NEW ZEALAND LTD.

Internet: <http://www.ralenti.co.nz/rinnai>

E-mail: fernerr@rinnai.co.nz

24 hr Service

Tel: (09) 625 4285 Fax: (09) 624 3018

Tel: 0800 746624 (0800 Rinnai)

691 Mt. Albert Road, Royal Oak, Auckland

P O Box 24-068