



Install a Rheem

Instruction Manual for Electric Storage Water Heater



MODELS: -

- ★ EHG-30
- ★ EHG-40
- ★ EHG-50
- ★ EHG-60
- ★ EHG-80
- ★ EHG-90
- ★ EHG-100
- ★ EHG-25S
- ★ EHG-40S
- ★ EHG-55S

Please Read This Manual Carefully Before Installation and Application

Rheem Manufacturing Co. Singapore Pte Ltd

Content

Thank you for choosing a Rheem Electric Storage Water Heater. This is the latest product of our company designed to provide you with hot water round the clock.

Please read this manual carefully before installation and usage. In particular, please pay special attention to the Safety and Warnings. The installation must be undertaken by an authorized person. Please leave this manual with the houseowner upon the completion of installation.

| | |
|-----------------------------------|----|
| 1. Features | 3 |
| 2. Safety | 3 |
| 3. Technical Data and Dimensions | 5 |
| 4. Installation and Connection | 6 |
| 5. Operation | 10 |
| 6. Maintenance | 10 |
| 7. Common Breakdowns and Remedies | 11 |
| 8. Limited Warranty | 11 |

Common breakdowns and remedies

| Breakdowns | Possible Causes | Remedies |
|---|---|--|
| No hot water flowing out | <ol style="list-style-type: none"> 1) Cold water inlet tap is shut off 2) Pipes are blocked 3) Water supply is cut off | <ol style="list-style-type: none"> 1) Turn on the inlet tap 2) Dredge the pipe by plumbers |
| Water is not hot | <ol style="list-style-type: none"> 1) Electric plug is off at the socket 2) Terminal block is damaged 3) ELCB has operated. Element has failed 4) ECO has activated (Hi Limit) 5) Temperature set is too low 6) Thermostat is damaged 7) Water Heater is working | <ol style="list-style-type: none"> 1) Plug in 2) Call electrician 3) Call electrician 4) Call electrician 5) Raise the set temperature 6) Call electrician 7) Please wait for a while |
| Sound from the water heater and pipelines | <ol style="list-style-type: none"> 1) Heating up noise 2) Abnormal sound in pipeline when mains pressure is not stable. 3) Scaling on elements | <ol style="list-style-type: none"> 1) Normal 2) Normal. Close the cold water inlet tap for a while. 3) Call for a serviceman |
| Pressure Relief valve discharge water | <ol style="list-style-type: none"> 1) Expansion of water during heating up 2) Valve is blocked by foreign materials 3) Excessive cold water pressure | <ol style="list-style-type: none"> 1) Normal 2) Operate valve lever to remove dirt deposit 3) Reduce incoming water pressure |

Limited Warranty

The standard warranty applicable for this Rheem product and the term of the warranty may differ based on the country of purchase. Depending on your country of purchase, the warranty may be provided by a member of the Rheem Manufacturing Company group of companies (hereinafter referred to as "Rheem") or by Rheem's authorized partners. Where the warranty is provided by Rheem's authorized partners, these partners shall be exclusively responsible for all warranty related services, including the term of the warranty.

Please contact your local Rheem retailer to enquire about the steps necessary to qualify for the applicable warranty and ensure that you complete those steps. Please ensure you retain a copy of your proof of purchase. For more information on the applicable warranty on your Rheem product, please contact your local Rheem retailer.

Rheem Water Heater

Rheem Manufacturing Company (Singapore) Pte Ltd

Revision Date: 2023 july

Operation

Filling the Water Heater

- Open one of the hot water mixer taps.
- Open the cold water tap to the water heater.
- When water flows out of the hot water mixer, it means that water heater is completely filled.

Warnings: Power must not be switched on until the water heater is filled with water. There will be NO WARRANTY for dry firing.

Using Hot Water

- The water heater operates on/off automatically.
- In normal condition, the cold water tap should remain open.
- It is normal for the pressure relief valve to release a small amount of hot water during the heating cycle due to expansion.
- Always open mixer to cold water first and slowly adjust to warm to avoid scalding.
- When water supply is interrupted, the main power supply to the heater should be switched off to avoid dry firing.

Shut off the Water Heater

The water heater should be shut off if it is serviced or it is not used for a long period of time. Shut off the water heater according to following steps:

- Remove the electric cable from socket or switch
- Shut off the stop tap of cold water inlet

Maintenance

Pressure Relief Valve

- Operate the Pressure Relief Valve at least once every six months to remove lime deposits and verify that it is not blocked. This is done by lifting the lever at the pressure relief valve for a few second. If there is no water flowing out, please call for a serviceman.
- Damage to the heaters due to blockage in the overflow pipe will void the warranty.

Features

- Operating at mains water pressure, providing stable hot water supply.
- Large storage capacity, deliver hot water simultaneously for multiple point usage.
- The thermostat automatically controls the power supply to the heating unit so that constant temperature is maintained.
- Safety devices such as over temperature cut out, and & pressure relief valve are standard features.
- The temperature is factory preset at 60°C for reasons of safety.
- The life span of the tank is greatly extended by enamel lining and sacrificial magnesium anode.
- Polyurethane foaming material free of CFC makes the water heater more efficient and cost-saving, and environmentally friendly.
- Colorbond jacket is rust-proof and fade resistant.

Safety

- This appliance is not intended for use by persons (including children) with reduced physical, sensory or mental capabilities, or lack of experience and knowledge, unless they have been given supervision or instruction concerning use of the appliance by a person responsible for their safety.Children should be supervised to ensure that they do not play with the appliance.
- CAUTION: In order to avoid a hazard due to inadvertent resetting of the thermal cutout, this appliance must not be supplied through an external switching device, such as a timer, or connected to a circuit that is regularly switched on and off by the utility.The water heater location must have a floor trap nearby for discharging water in the event that the water heater or pipe leaks
- The water heater is powered to 220~240VAC/50/60Hz.

- Electricity meter, power cables and terminal block must comply with rated electric current.
- A separate terminal block must be applied. The terminal block should have an earth connection that is strictly separated from the neutral. Please see “Electrical Connection” for more details.
- Keep the terminal block and electric plug in a dry place. Do not touch electric plug with wet hands!
- Power must not be turned on until the water heater is filled with water.
- Temperature over 50°C may cause scalding! Please mix cold water with hot water to desirable shower/bath temperature.
- Please operate the pressure relief valve at least once every six month to remove the lime deposits and verify that the drain pipe is not blocked.
- Blockage of overflow pipe will lead to tank expansion! Warranty is void!
- Power must be turned off before any service and maintenance work can commence!
- Any replacement of parts must be original parts from the manufacturer!
- Water may drip from the discharge pipe of the pressure relief valve. The discharge pipe should be connected to an overflow discharge pipe and be left open to the atmosphere.
- The water in heater can be drained by following steps:
 1. Turn off the power supply
 2. Turn off the incoming water supply
 3. Turn on one hot water faucet
 4. Lift PRV lever. Water will drain off form heater.
 5. Reverse procedures to fill up heater again.

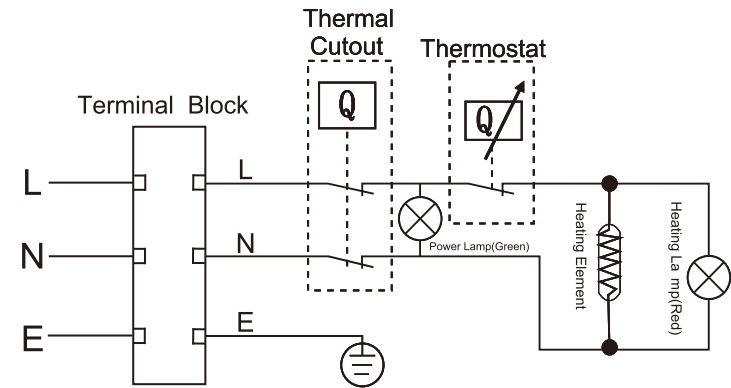

Diagram 6 Electrical connection

WARNING: IMPROPER INSTALLATION WILL VOID ALL APPLICABLE WARRANTIES.

Fully tighten the terminal block screws.

Ensure no cable insulation is trapped under screws.

Loose connections may result in cable overheating causing damage to terminal block and heater.

Option A

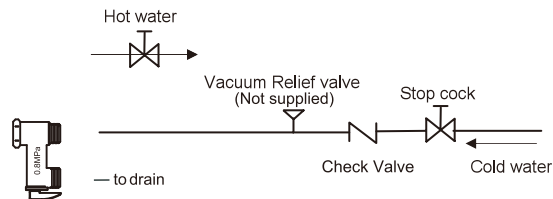

Option B

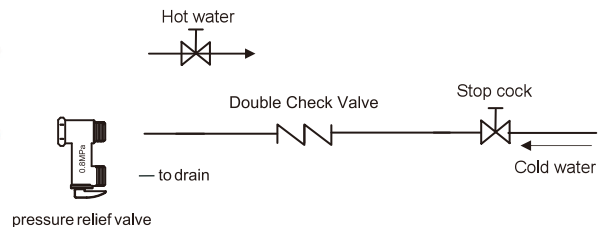

Diagram 5

- Pressure Relief valve drain
A drainpipe must be fitted for the water discharge. The pipework from the pressure relief valve to the floor trap should be as short as possible, with no restrictions. It should have no more than three right angle bends in it. Use 15mm OD(1/2") pipe.

Connection—Electrical

Do not turn on power supply to the water heater until the water heater is filled with water and a satisfactory megger reading is obtained.

- Electrical wiring works must be undertaken by a qualified electrician.
- The water heater is rated for single phase 220-240VAC, 50/60Hz.
If fixed wiring connection, all wires used must be at least 3 x Ø2.5mm².
- The heater must be permanently connected to the electricity supply through a double pole linked switch having a contact separation of at least 3 mm in all poles incorporated in the circuit and out of reach from the person using the shower.
 - The use of plug and socket is not recommended.
 - The appliance must be earthed.
 - All wiring must conform to local requirements. If in doubt, please consult a qualified electrician.
 - The heater must be connected to its own independent electrical circuit from Distribution Board (DB) or miniature circuit breaker (MCB) to a 10mA RCD (Malaysia requirement).

Technical Data and Dimensions

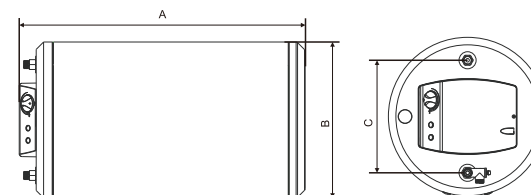

Diagram 1

| Model Number | | EHG-30 | EHG-40 | EHG-50 | EHG-60 | EHG-80 | EHG-90 | EHG-100 |
|---------------------------------|-----|------------------------|--------|--------|--------|--------|--------|---------|
| Rated Storage | L | 30 | 40 | 50 | 60 | 80 | 90 | 100 |
| Rated Power | kW | 3000W | | | | | | |
| Rated Electric Current | A | 12.5A | | | | | | |
| Length A | mm | 500 | 600 | 700 | 820 | 940 | 1025 | 1140 |
| Diameter B | mm | Ø380 | Ø380 | Ø380 | Ø380 | Ø410 | Ø410 | Ø410 |
| C | mm | 270 | | | 300 | | | |
| Power Supply | | 220 - 240V ~ / 50/60Hz | | | | | | |
| Temp. Setting | °C | 60°C | | | | | | |
| Pressure Relief Valve | kPa | 800 | | | | | | |
| Max inlet water pressure | kPa | 800 | | | | | | |
| Min inlet water pressure | kPa | 80 | | | | | | |
| Pipe sizes for inlet and outlet | | 1/2" /15 BSP | | | | | | |
| Pipe size for safety valve | | 1/2" /15 BSP | | | | | | |
| Shipping Weight | kg | 17 | 21 | 22 | 24 | 28.5 | 30 | 32 |

- Due to product improvement, please check that installation manual has been updated.

Technical Data and Dimensions

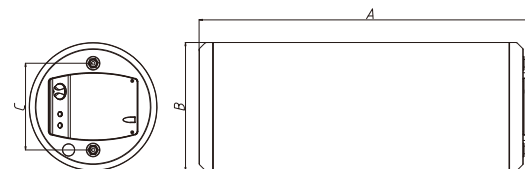

Diagram 2

| Model Number | | EHG-25S | EHG-40S | EHG-55S |
|---------------------------------|-----|------------------------|---------|---------|
| Rated Storage | L | 25 | 40 | 55 |
| Rated Power | kW | 3000W | | |
| Rated Electric Current | A | 12.5A | | |
| Length A | mm | 645 | 775 | 935 |
| Diameter B | mm | Ø340 | Ø340 | Ø340 |
| C | mm | 230 | | |
| Power Supply | | 220 - 240V ~ / 50/60Hz | | |
| Temp. Setting | °C | 60°C | | |
| Pressure Relief Valve | kPa | 800 | | |
| Max inlet water pressure | kPa | 800 | | |
| Min inlet water pressure | kPa | 80 | | |
| Pipe sizes for inlet and outlet | | 1/2" /15 BSP | | |
| Pipe size for safety valve | | 1/2" /15 BSP | | |
| Shipping Weight | kg | 16.7 | 19 | 22.3 |

- Due to product improvement, please check that installation manual has been updated.

Installation and Connection

Choose where to install

- The water heater must be installed indoor.
- The wall must be strong enough to support heater.
- The heater is to be installed near to points of use.
- Ensure that sufficient space is available for servicing.
The distance between the right end of the heater and the adjacent wall must not be less than 500mm.
- There must be a floor trap near installation point for the heater drain pipe.
- Water heater/power switch/electric leakage protector should be protected against water.

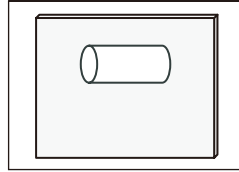

Diagram 2

Installation

- Mark the drilling position for locating expansion bolts on the wall or ceiling as shown in diagram 3. The two upper holes must be in the same horizontal line.

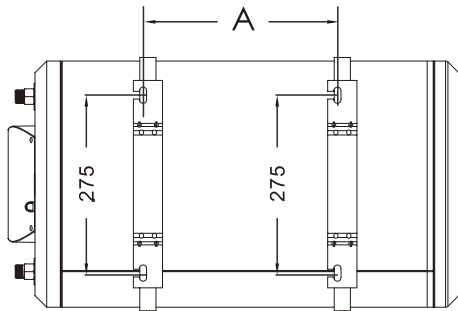
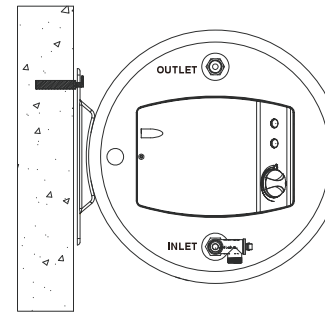

Diagram 3

| Type | Hole Space, A |
|------|---------------|
| 25L | 220 mm |
| 30L | 165 mm |
| 40L | 280 mm |
| 50L | 400 mm |
| 55L | 500 mm |
| 60L | 500 mm |
| 80L | 500 mm |
| 90L | 500 mm |
| 100L | 500 mm |

- Drill holes on the wall using a 12mm drill bit (do not damage the electric cable and pipe work inside the wall), then screw in expansion bolts and fasten the hooks on the wall.
- Hang up the heater as shown in Diagram 4. The mounted heater must be horizontal.
- Use ST4.2 self-tap screw to secure the water heater to the universal brackets.

Optional:



wall hung

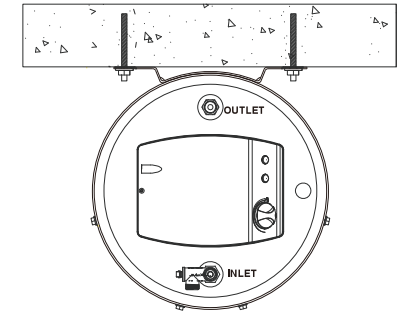

ceiling hung

Diagram 4

Connection—Plumbing

- **Pipe Material**
The pipes connecting to the inlet and outlet of the water heater must be strong enough to withstand water pressure up to 1.40 MPa.
- **Connection**
Both the inlet and outlet are located at the end of the water heater, with the upper connection being outlet and lower connection being inlet. The cold water tap is fitted to the inlet as shown in diagram 5. As the temperature is high at the outlet, a mixing valve which mixes hot water with cold water is suggested to be fitted. If the outlet tap is not close to the water heater, thermal insulation material is recommended to insulate the hot water pipe so as to reduce heat loss.

If the mains pressure is too low, the amount of hot water delivered to multiple points will be unsatisfactory. Thus a booster pump is suggested to be increase the pressure. A pressure-limiting valve is suggested to be fitted if the main pressure exceeds the rated maximum pressure.